

Renault Clio III (2005-2012)
Renault Clio IV (2012-2017)

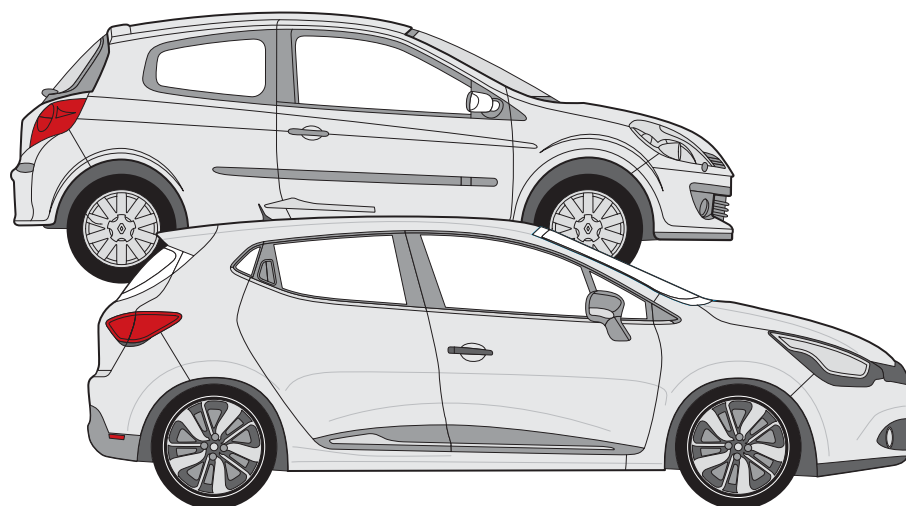

ECE/R55

Renault Clio III (2005-2012)
Renault Clio IV (2012-2017)

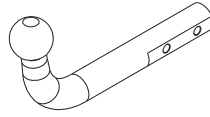

E13	APPROVALNUMBER	D-VALUE
	55R-01 3572	D 6,96 kN
	TYPE CLASS	MAX.VERT.LOAD
RNL057	A50-X	S 75 kg

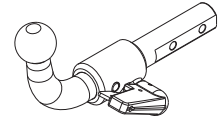

E13	APPROVALNUMBER	D-VALUE
	55R-01 3573	D 6,96 kN
	TYPE CLASS	MAX.VERT.LOAD
RNL058-S	A50-X	S 75 kg

D= 6,96 kN



T= 1300 Kg



S= 75 kg

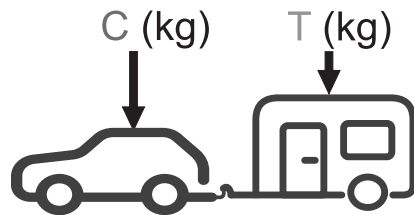
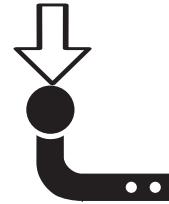

$g = 9,81 \text{ m/s}^2$

$$D \geq \frac{T \cdot C}{T+C} \cdot \frac{g}{1000} \text{ (kN)}$$





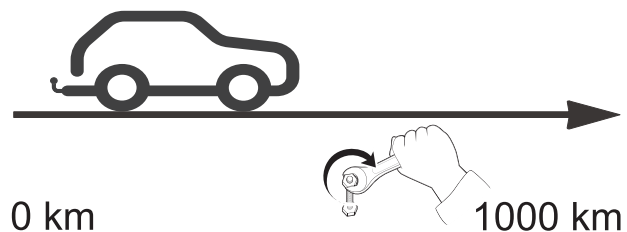

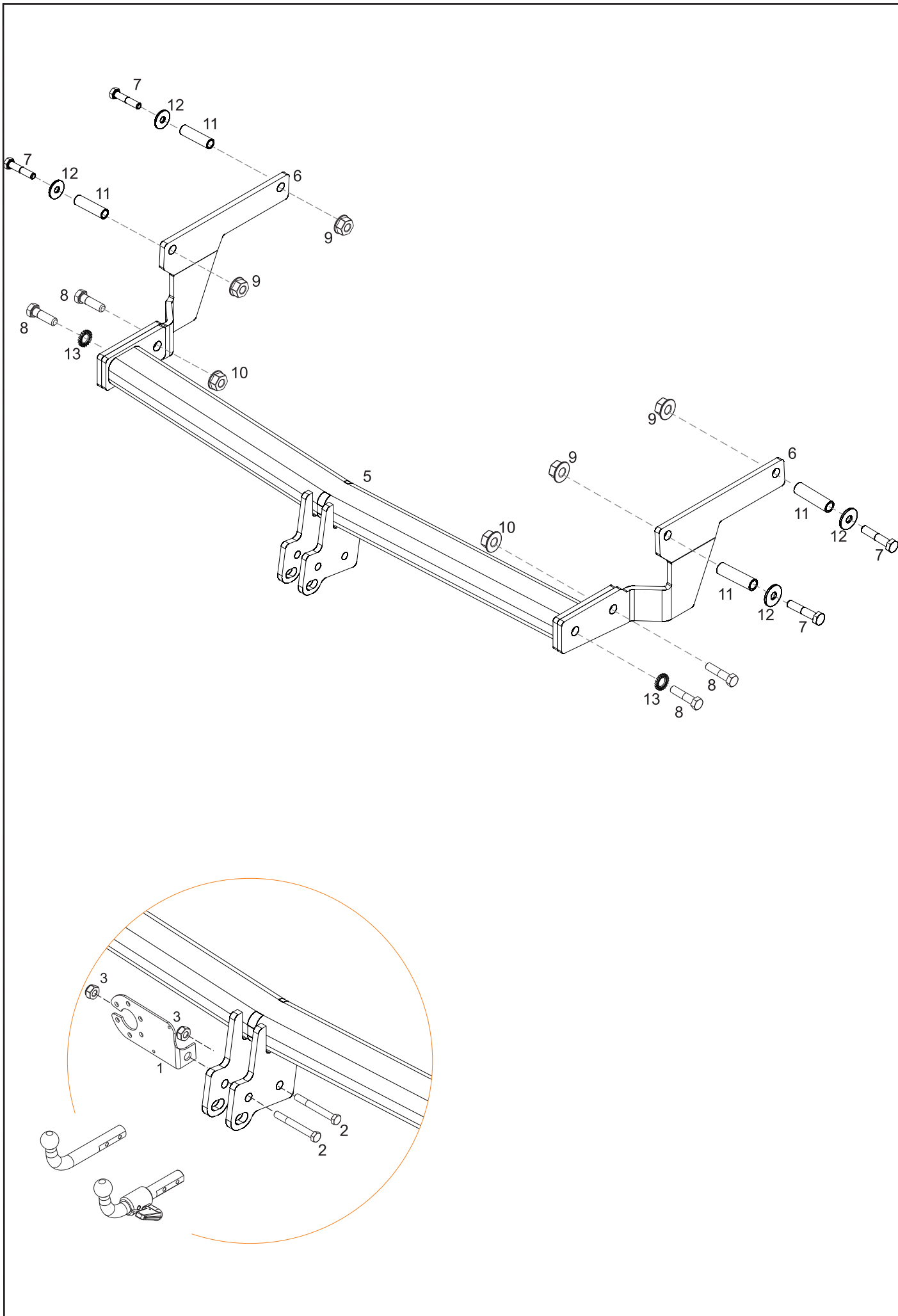

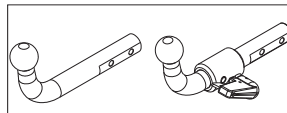

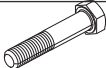
$$T \leq \frac{C \cdot D \cdot 1000}{(C \cdot g) - (1000 \cdot D)} \text{ (kg)}$$

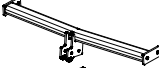
	M8	M10	M12	M14	M16
N/m	20	40	60	105	160

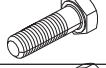
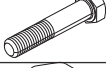





1			1	
2		M10x65 DIN 931(8.8)	2	
3		M10 DIN 980	2	
4			1	
5			1	
6		C5213DA21	1+1	
7		M10x90 DIN 933(8.8)	4	
8		M12x40 DIN 933(8.8)	4	
9		M10 DIN 6923	4	
10		M12 DIN 6923	2	
11		18x58	4	
12		Ø12 DIN 9021	4	
13		Ø12 DIN 6798	2	

1

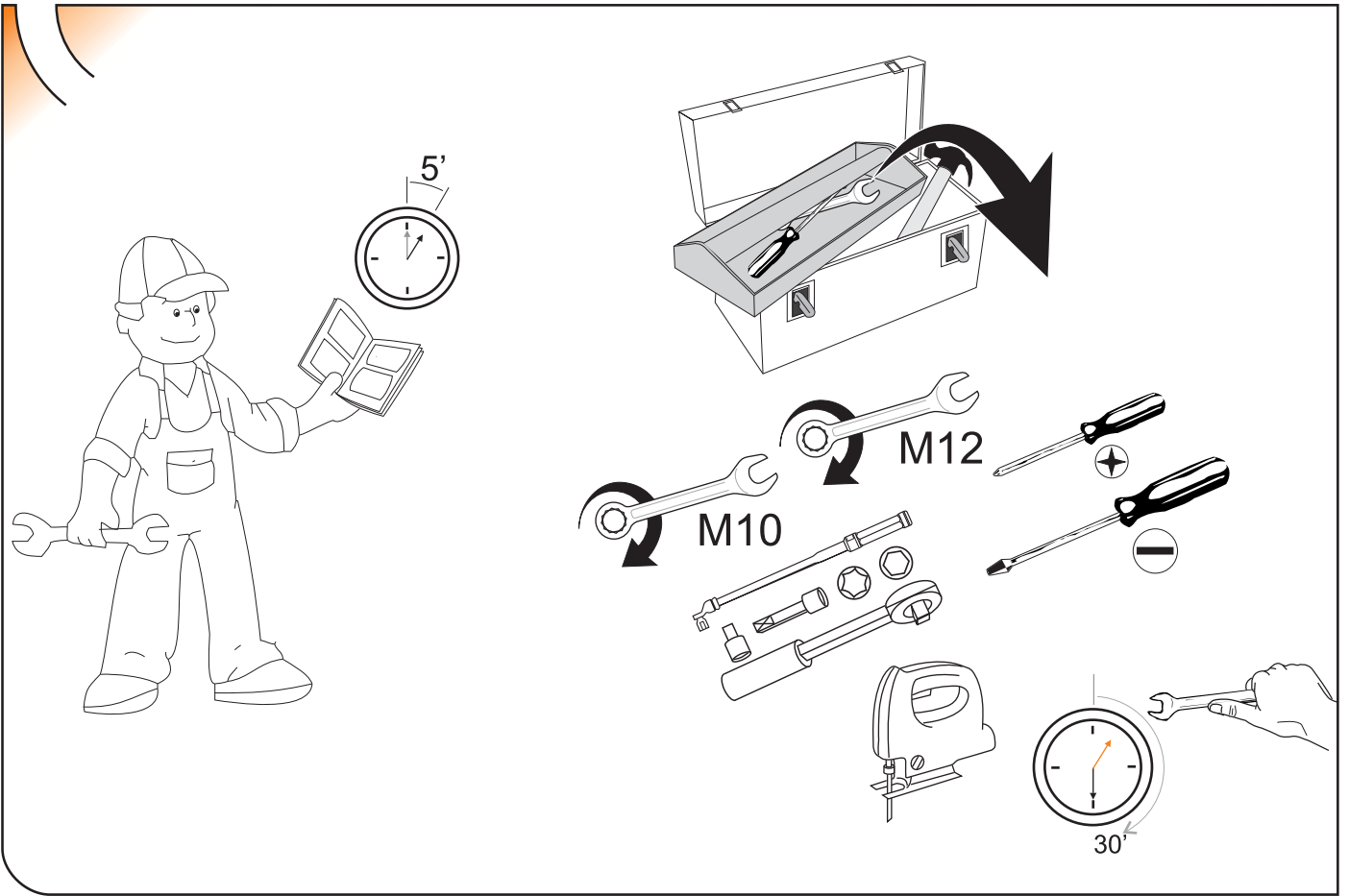

2

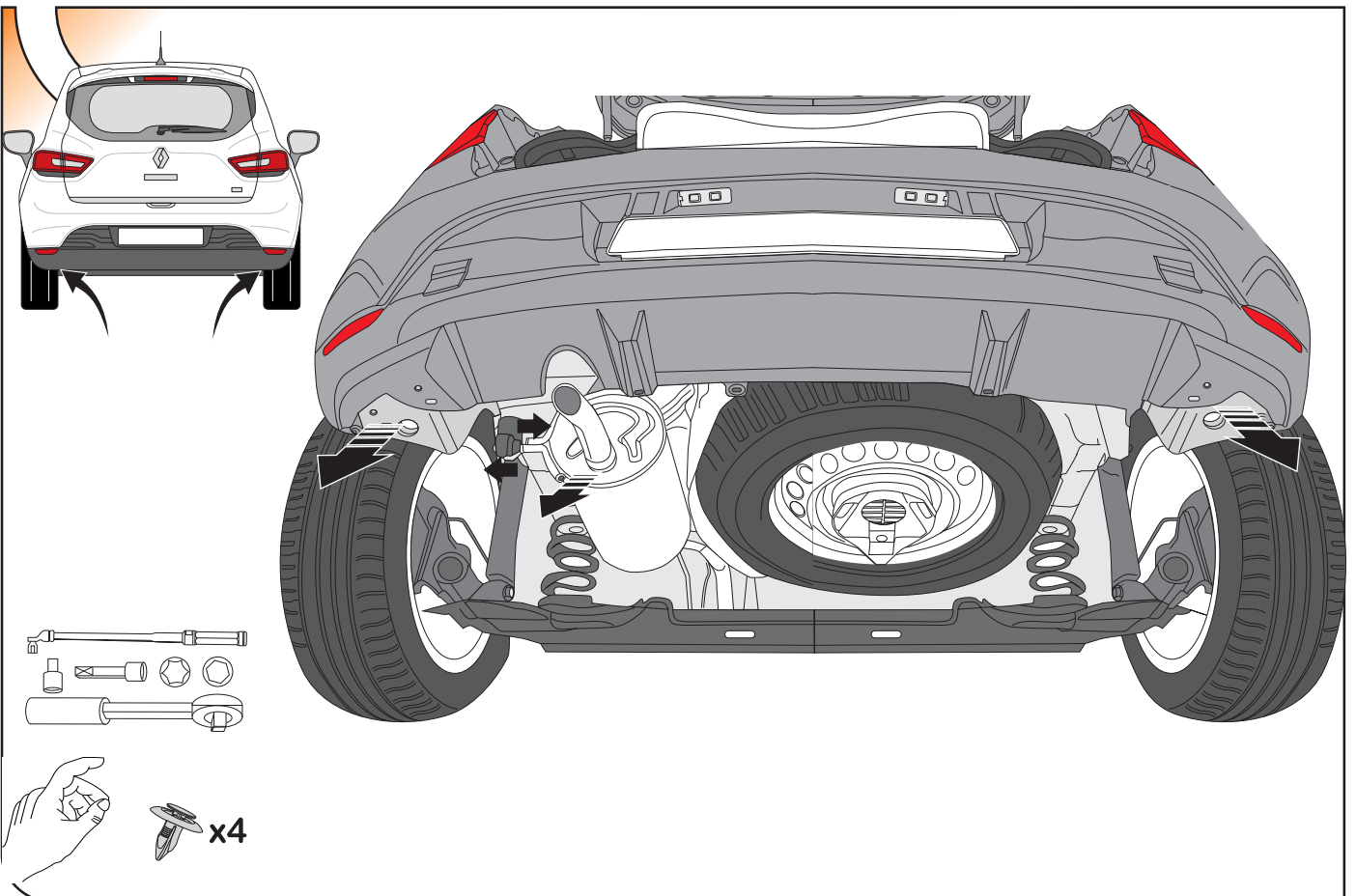

3

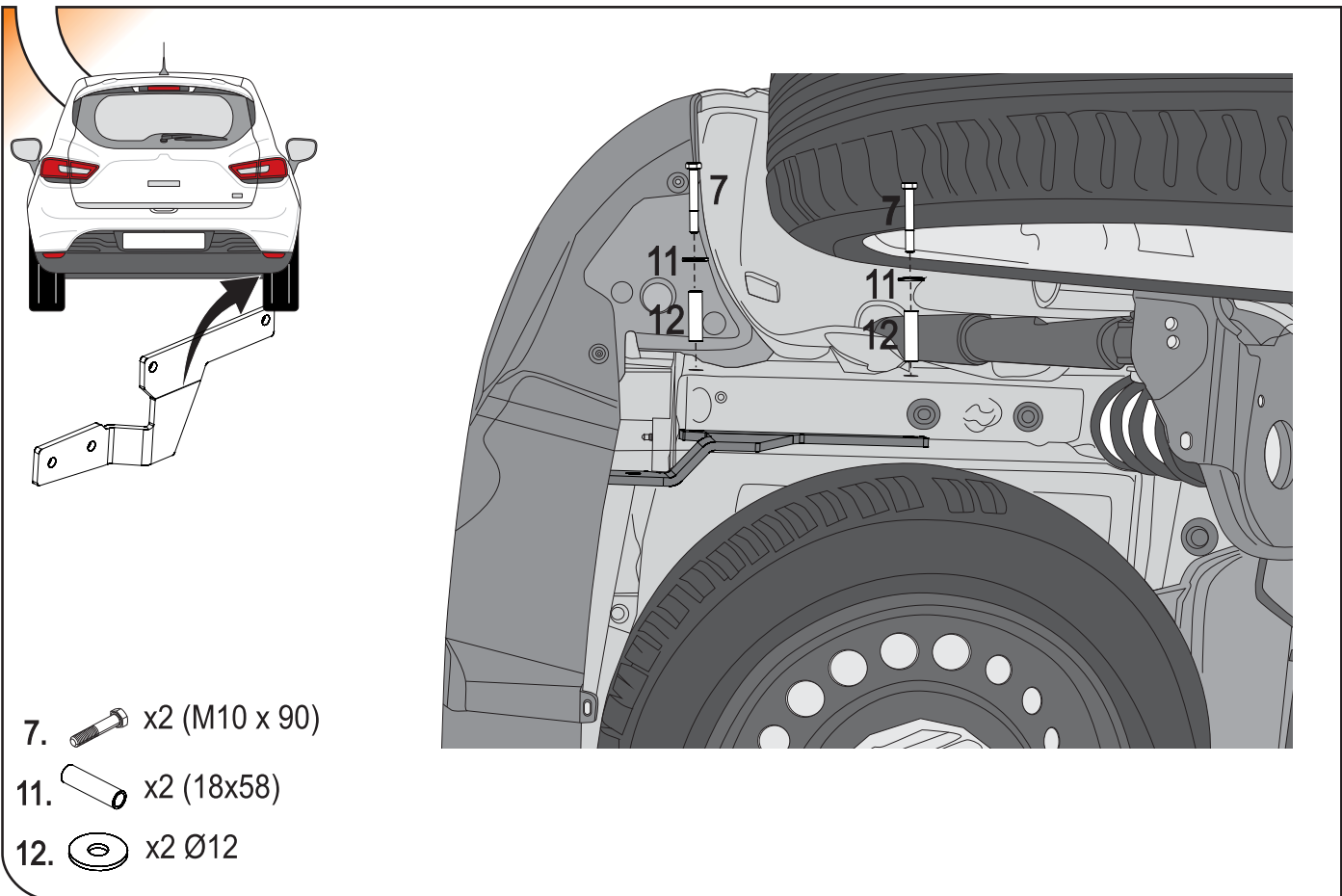

4

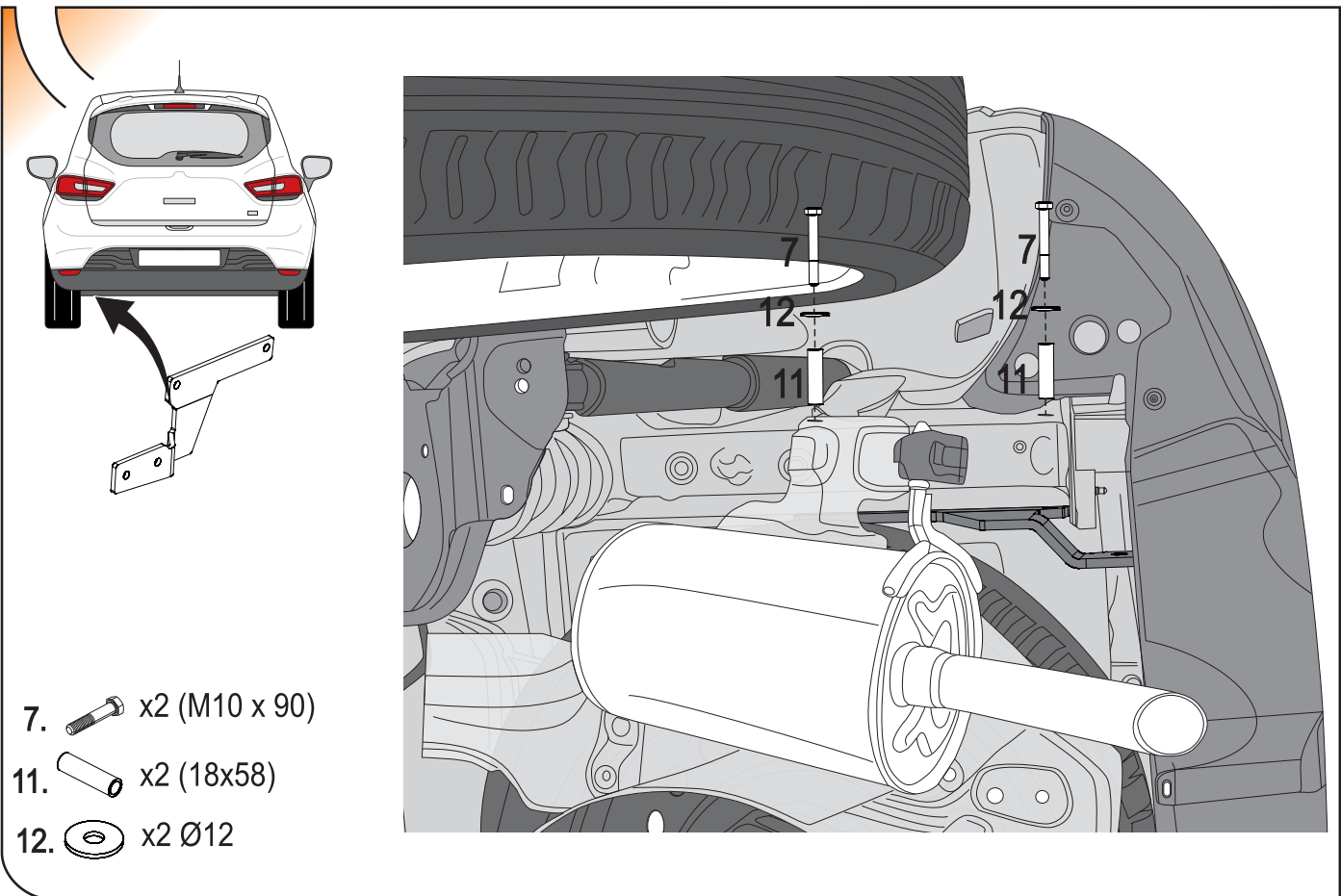

5

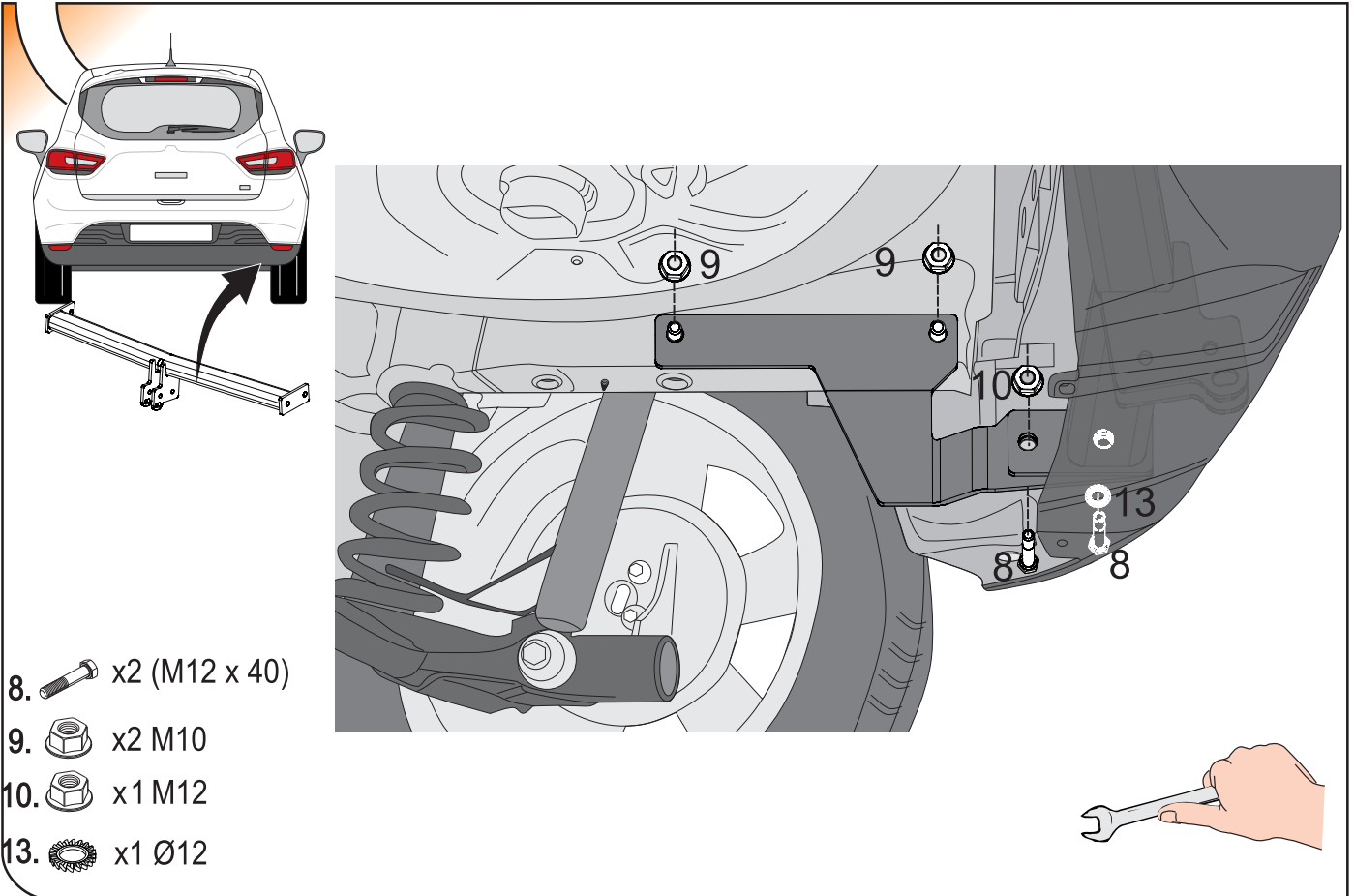

6

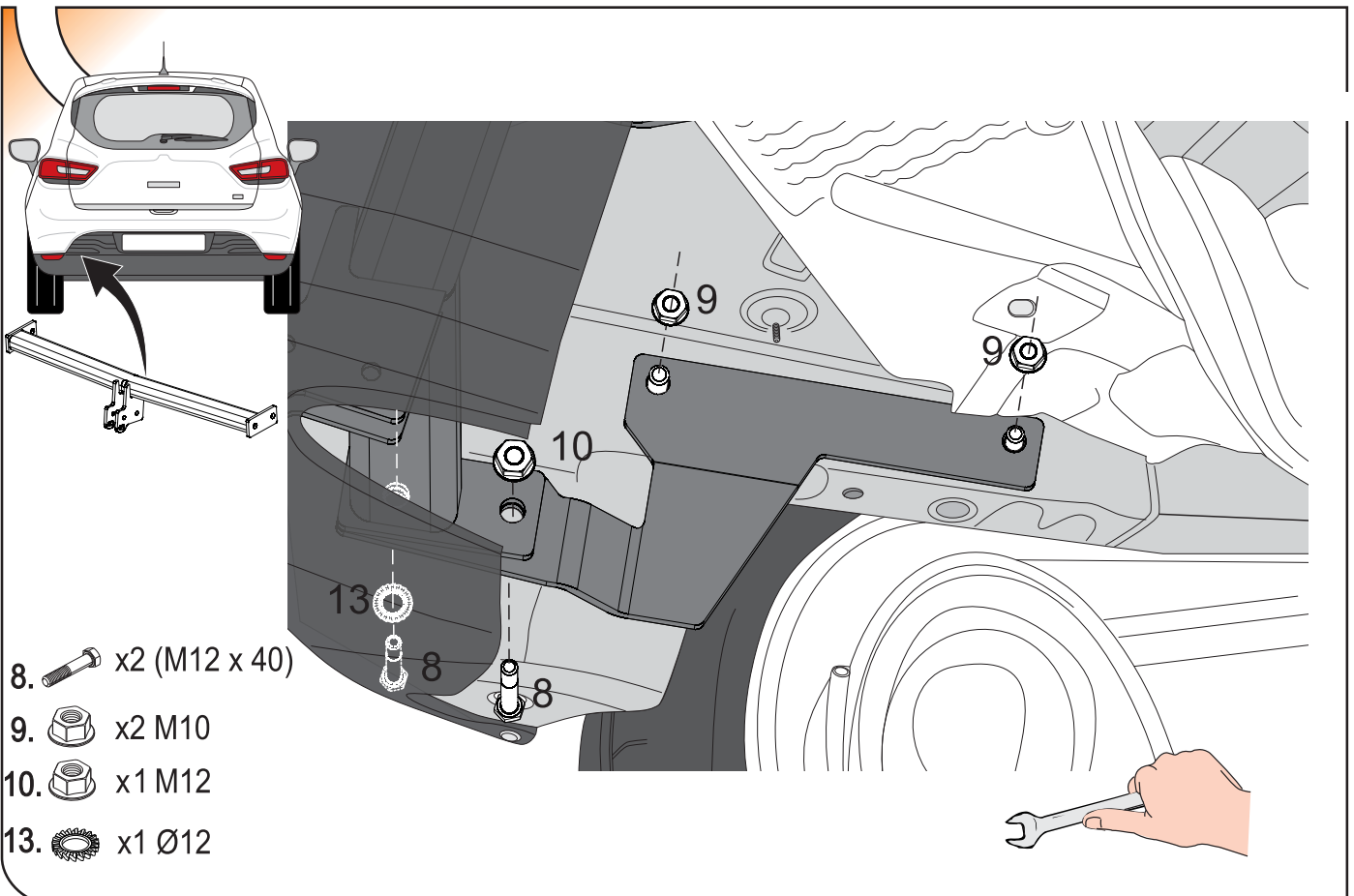

7

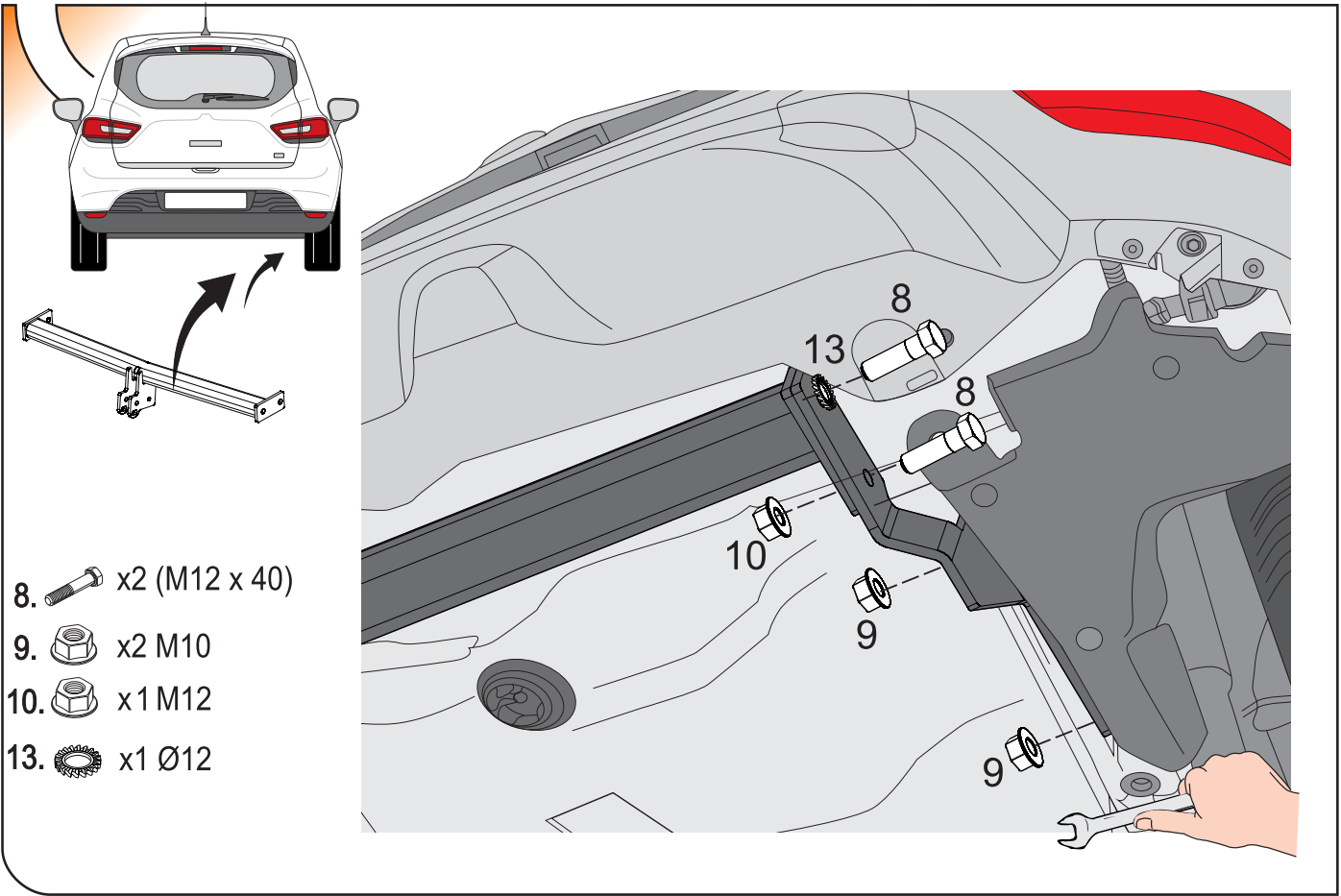

8

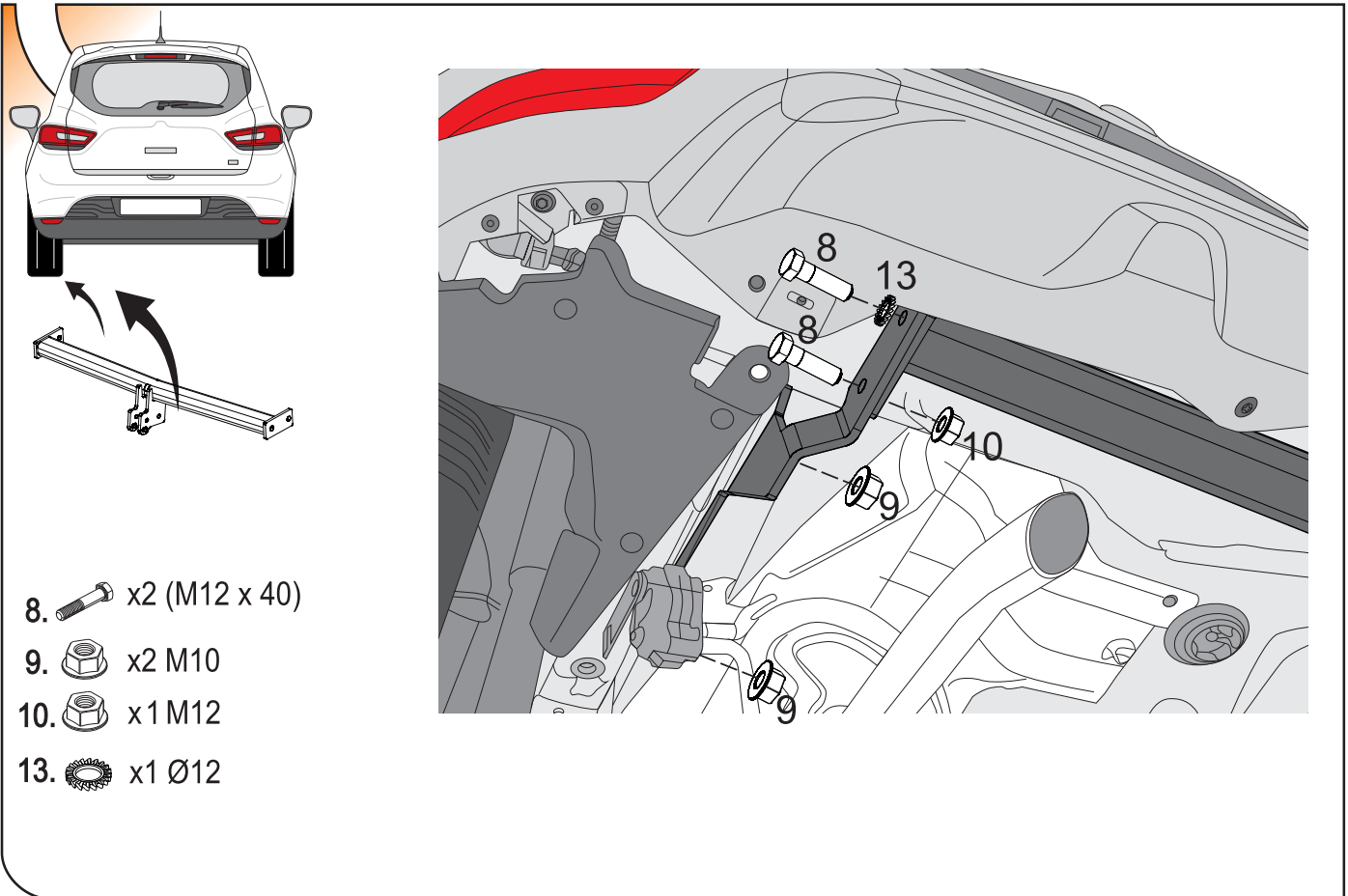

9

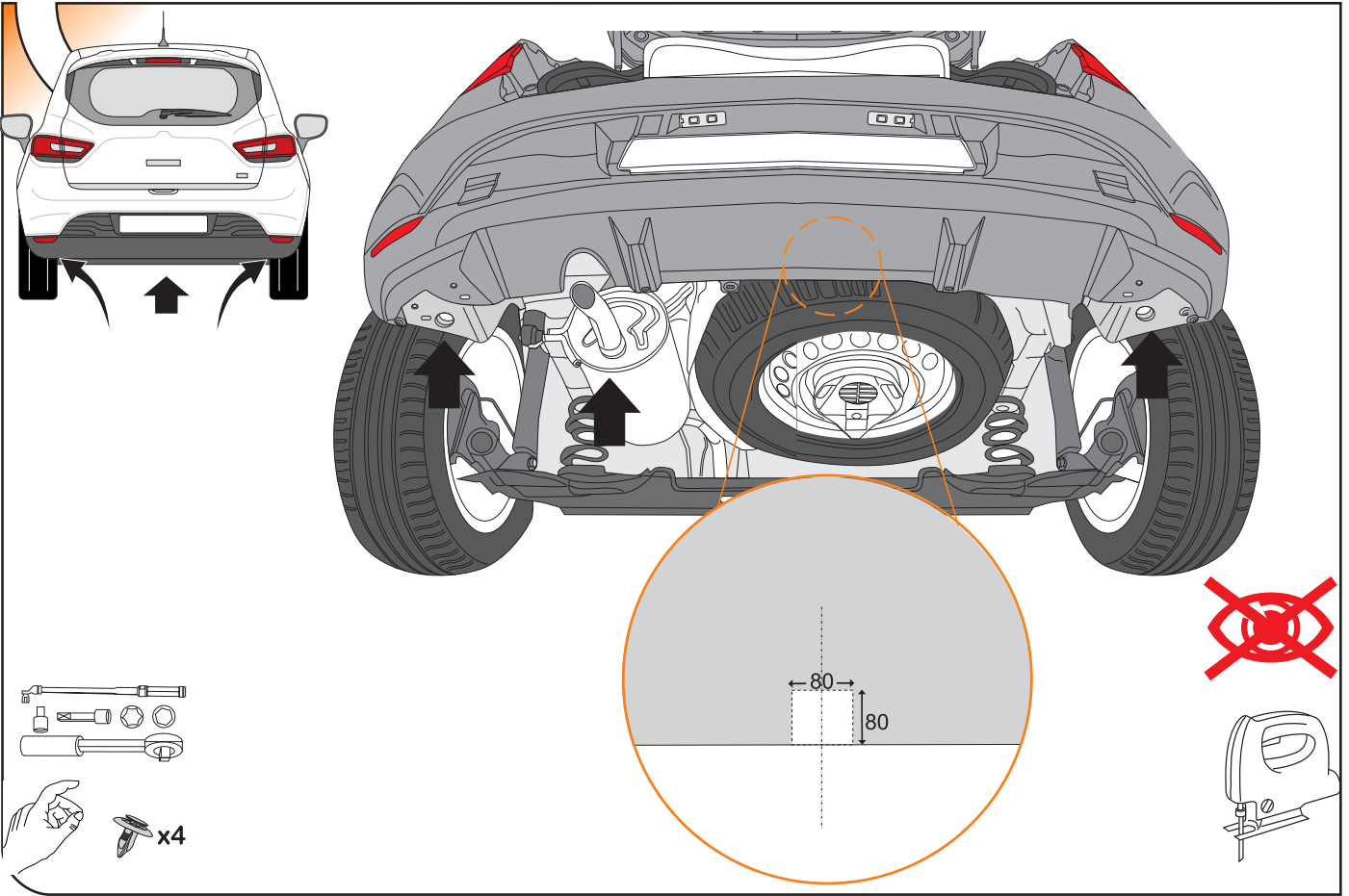

10

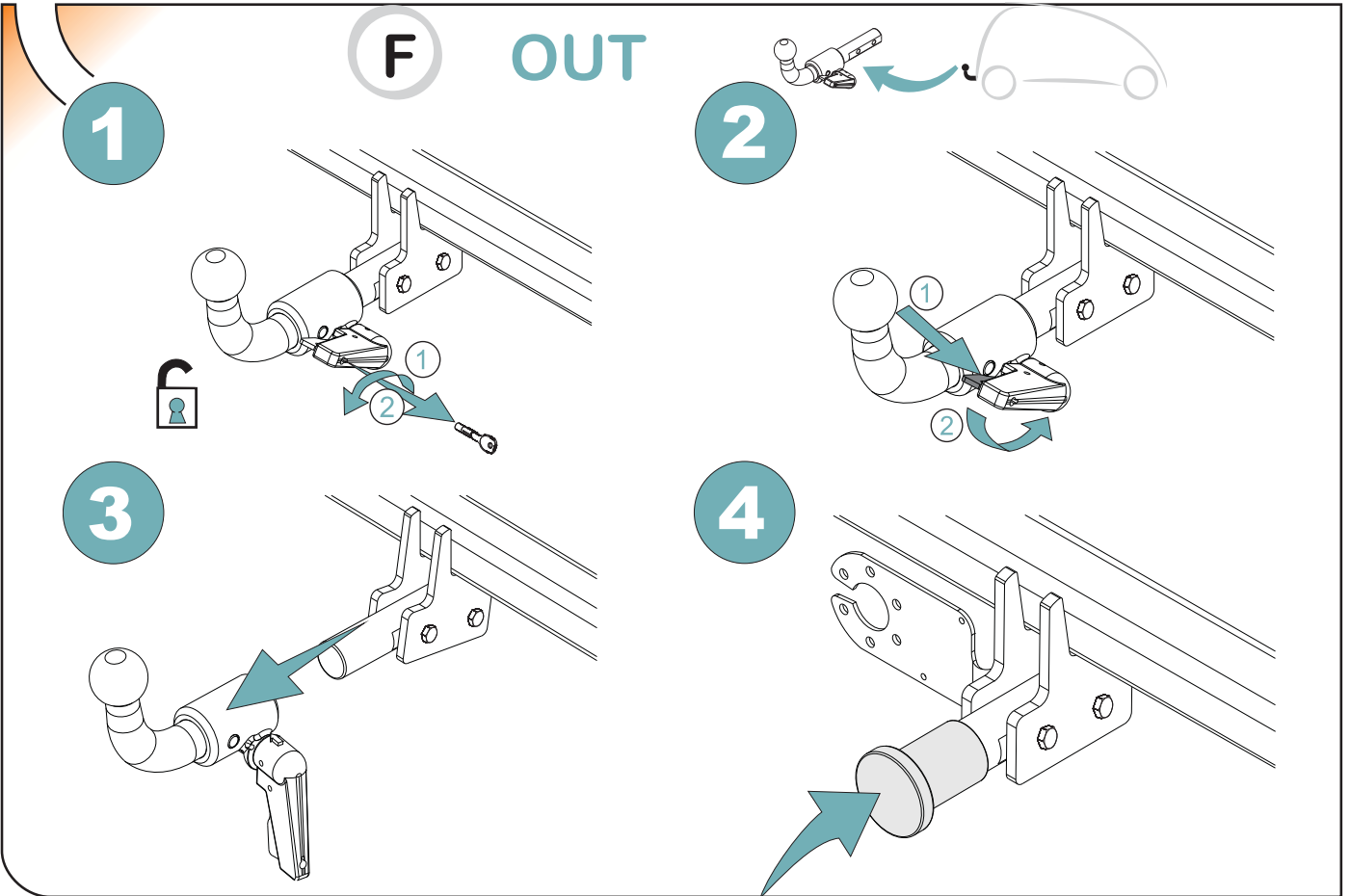

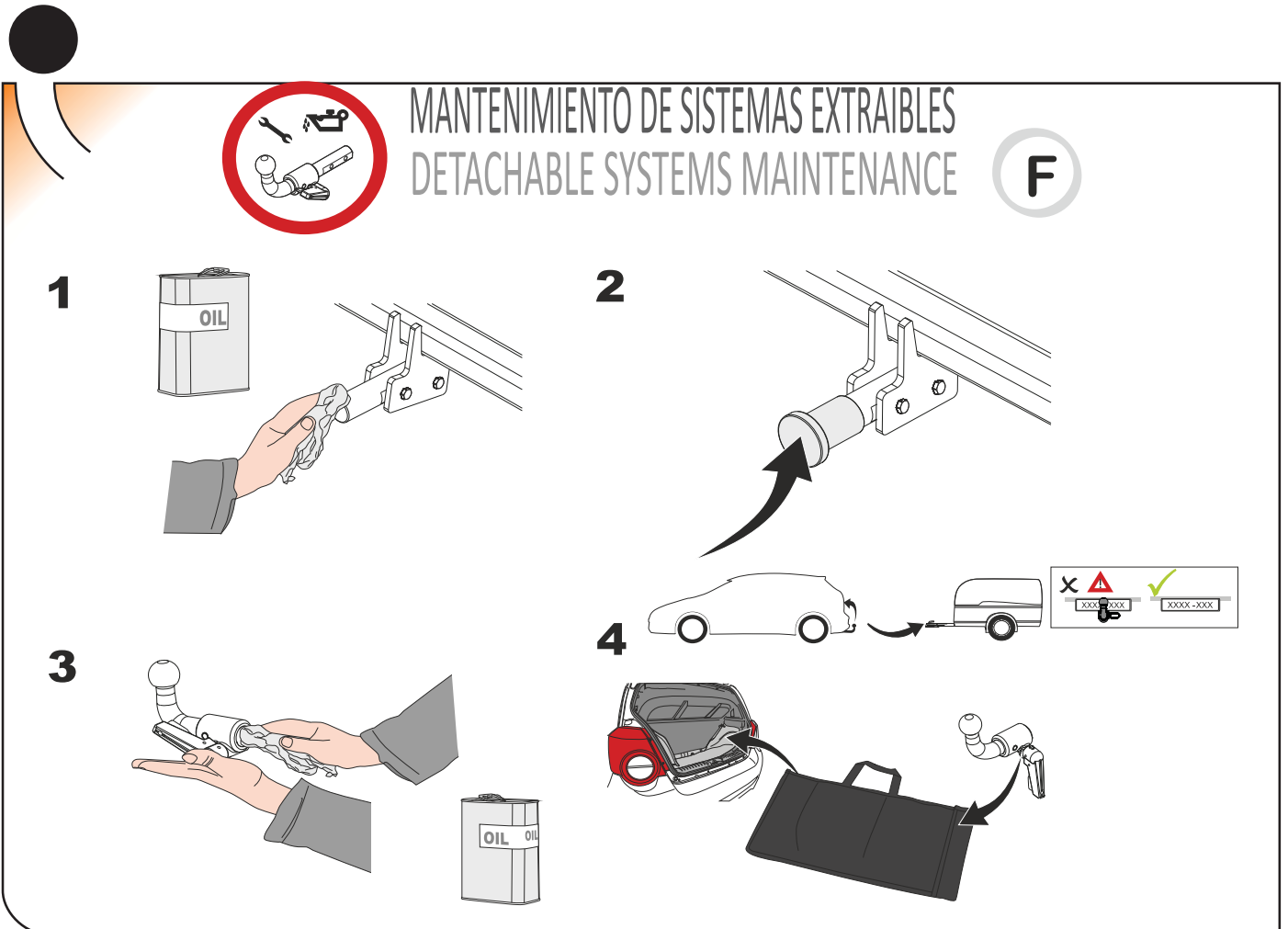
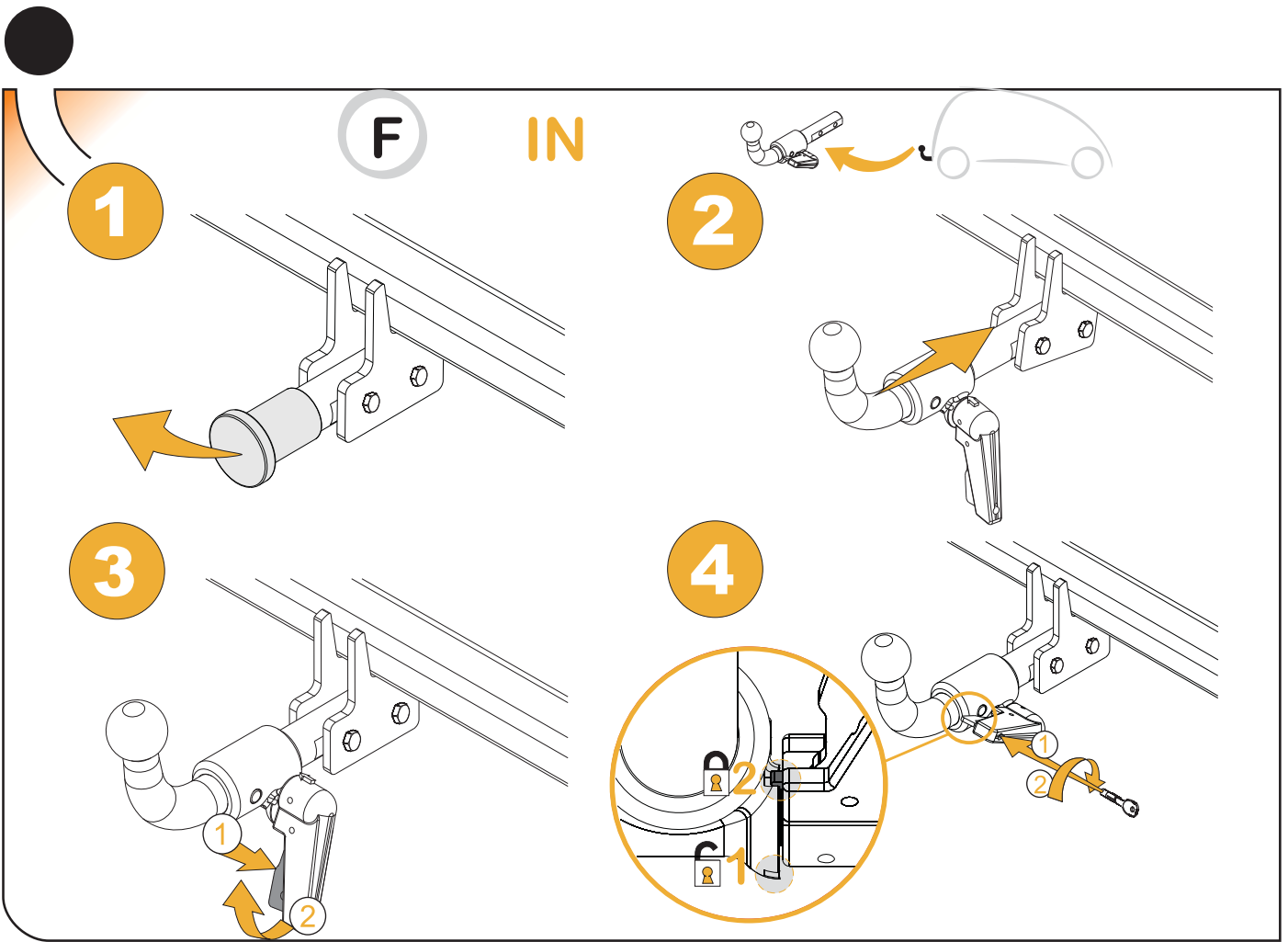

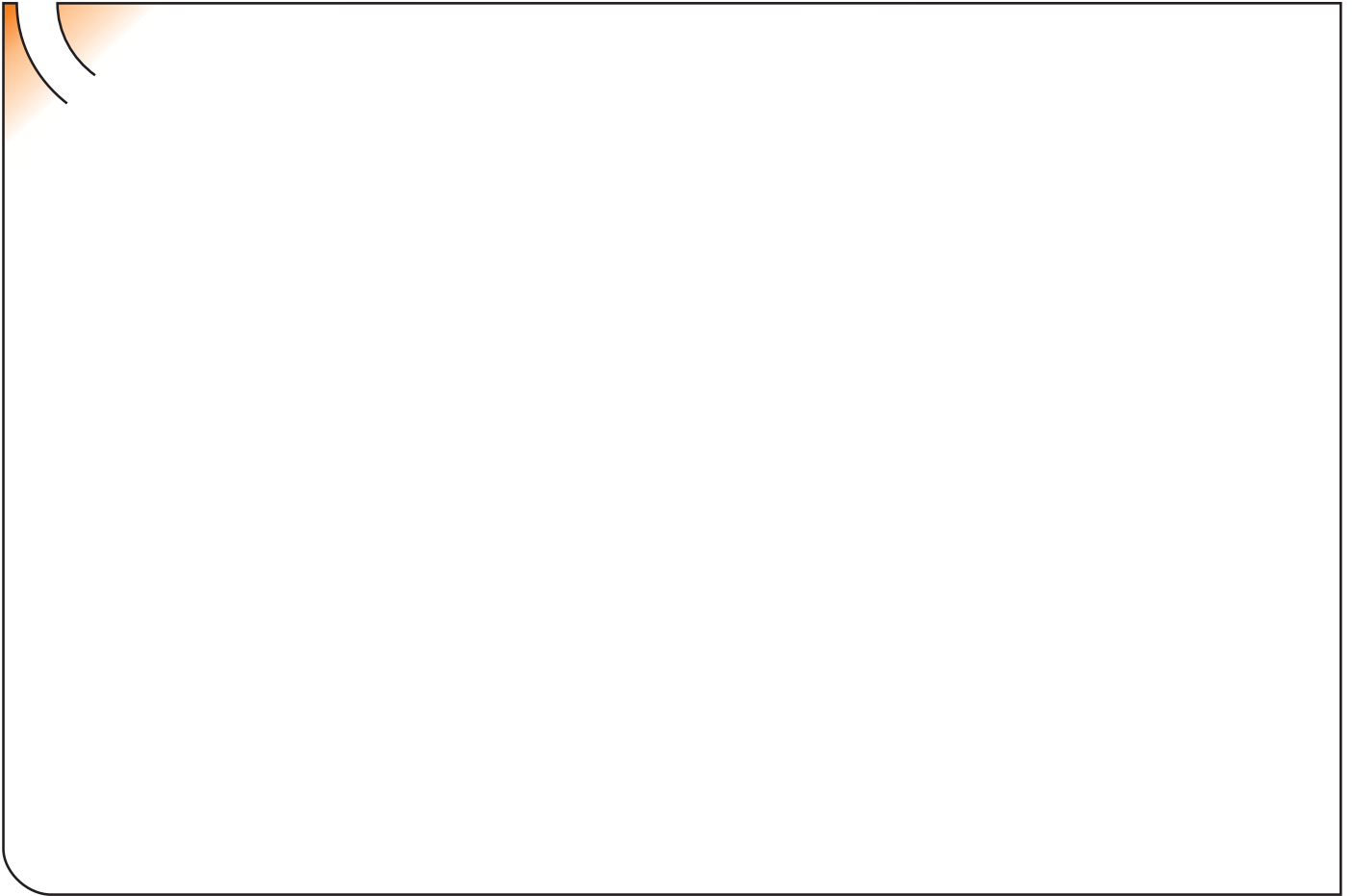

ANEXO III

CERTIFICADO DE TALLER

D. _____, expresamente autorizado por la _____
domiciliada en _____, teléfono _____, dedicada
a la actividad de _____ n° de Registro Industrial _____ y n° de registro
especial _____.

CERTIFICA

Que la mencionada empresa ha realizado la/s Reforma/s y asume la responsabilidad de la ejecución,
sobre el vehículo marca....., tipo.....
variante..... denominación comercial
matrícula y n° de bastidor, de acuerdo con:

- La normativa vigente en materia de reformas de vehículos.
- Las normas del fabricante del vehículo aplicables a la/s reforma/s llevadas a cabo en dicho vehículo.
- El proyecto descriptivo de la/s reforma/s, adjunto al expediente.

OBSERVACIONES: (2)

Tipificada/s con el código de reforma/s.....
Reforma consiste en:

COLOCACION DE ENGANCHE _____

n° de identificación / marca de homologación

Type :

Fecha:

Firma y sello:

Fdo:

(1) En el caso de que la reforma sea efectuada por el fabricante se indicará N/A.

(2) Se debe especificar en este apartado OBSERVACIONES, la identificación de los equipos o sistemas modificados, garantizando que se cumple lo previsto en el artículo 6 del reglamento general de vehículos y, en su caso, en el artículo 5 del R. D. 1457/1986 de 10 de enero, por el que se regula la actividad industrial en talleres de vehículos automóviles, de equipos y sus componentes, modificado por 455/2010 de 16 de abril, por el que se modifica el R. D. 1457/1986 de 10 de enero por el que se regulan la actividad industrial y la prestación.

ES

1



2

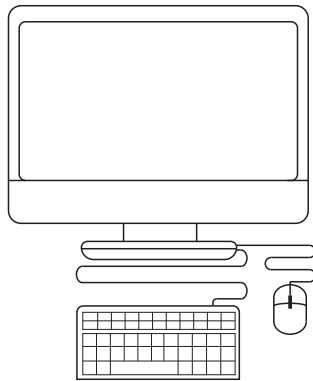

3



IT

1

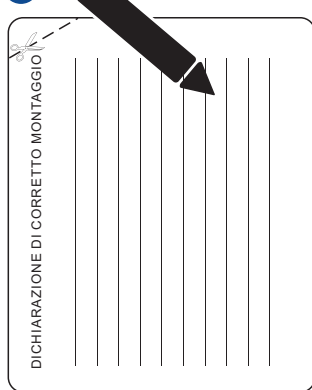

2

