

Porsche Panamera (2017-)

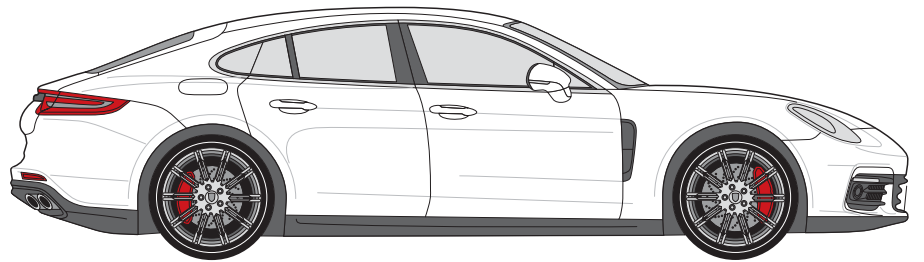

ECE/R55

Porsche Panamera (2017-)

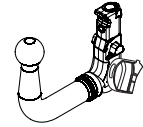

E13	APPROVALNUMBER	D-VALUE
	55R-01 4486	D 11,9 kN
	TYPE	CLASS
	POR002-V	A50-X
		MAX.VERT.LOAD
		S 100 kg

D= 11,9 kN



T= 2200 Kg



S = 100 kg

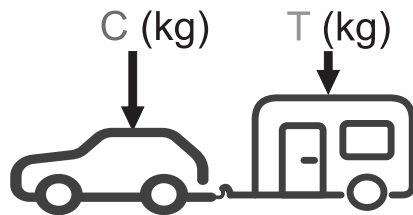
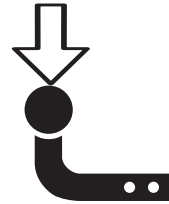

$g = 9,81 \text{ m/s}^2$

$$D \geq \frac{T \cdot C}{T+C} \cdot \frac{g}{1000} \text{ (kN)}$$

$$T \leq \frac{C \cdot D \cdot 1000}{(C \cdot g) - (1000 \cdot D)} \text{ (kg)}$$

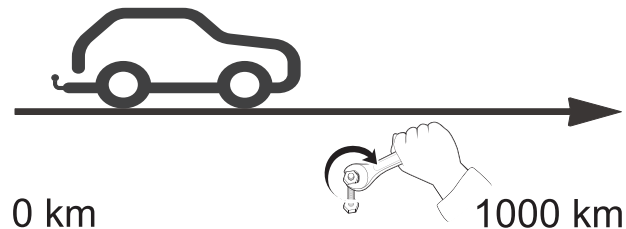
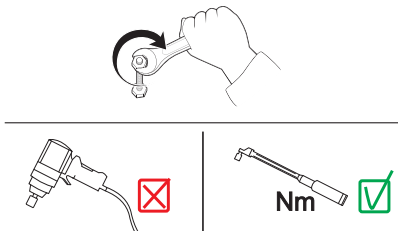

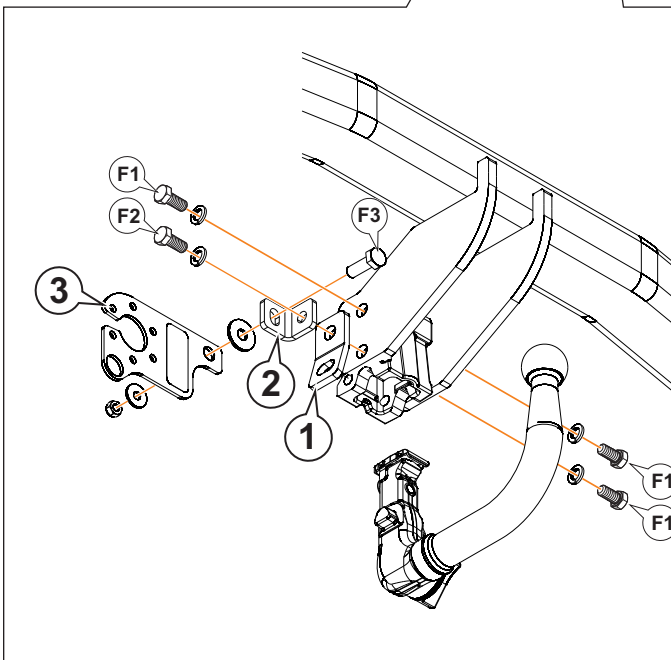
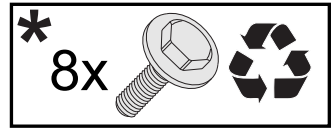
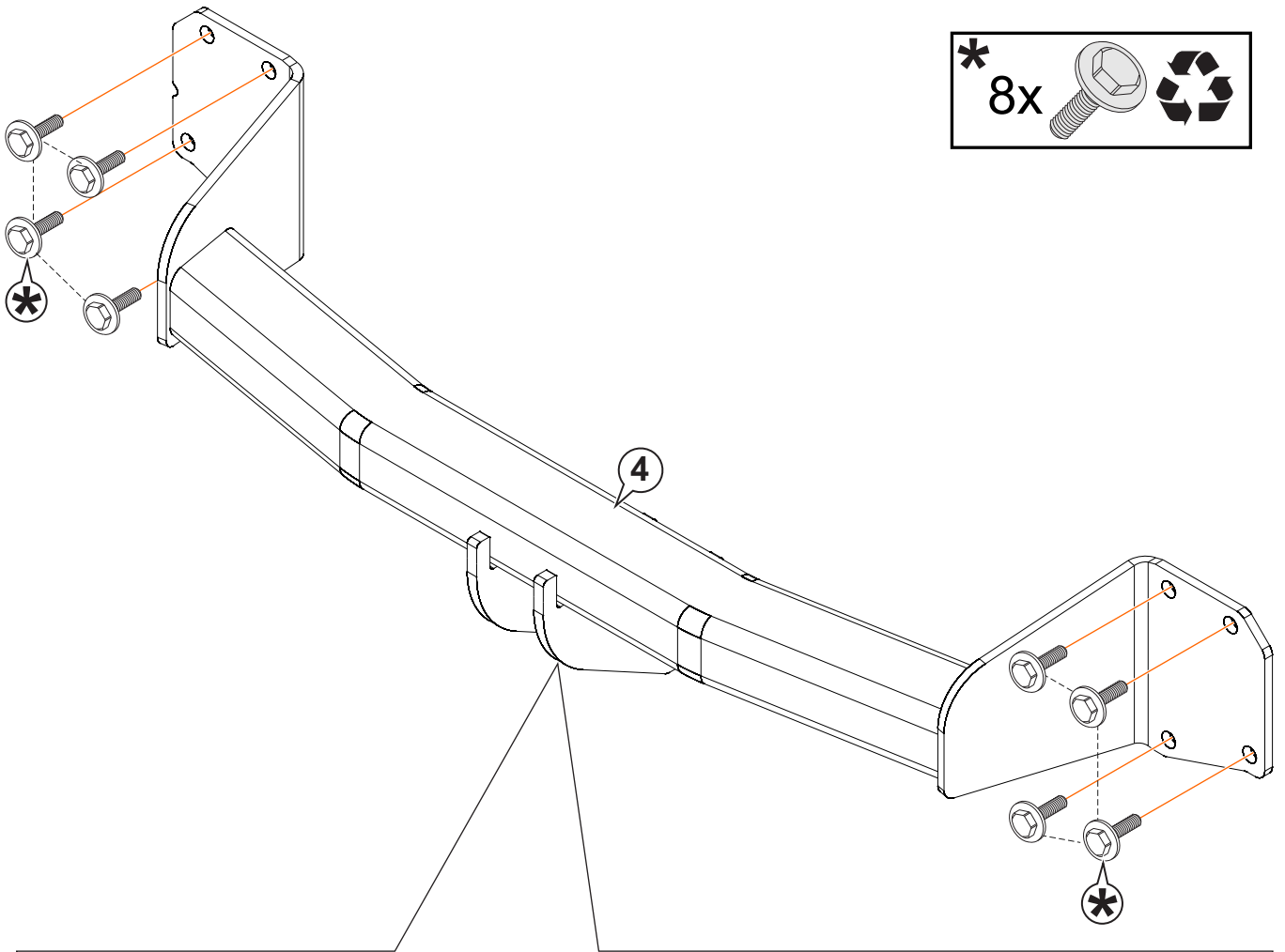



		#
F1	M12 x 25 DIN 933	3
	Ø12 Grower DIN 128	3
F2	M12 x 35 DIN 933	1
	Ø12 Grower DIN 128	1
F3	M10 x 30 DIN 933	1
	Ø10 Poliuretano / Nylon	1
	Ø10 DIN 9021	1
	M10 DIN 980	1

M12 → N/m 65
M10 → N/m 40

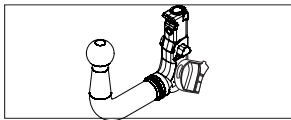
F1	M12 (8.8)
F2	M12 (8.8)
F3	M10 (8.8)

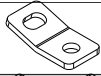
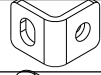

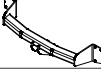
1		AEV0006	1	
2		AEV0008	1	
3		AEV0009	1	
4		C4900BV60	1	

1

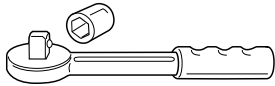
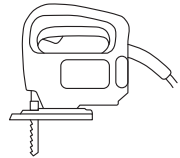
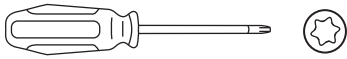
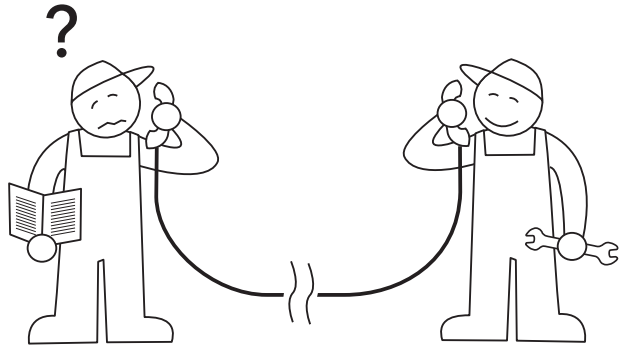
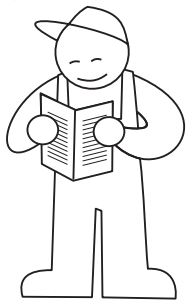

2

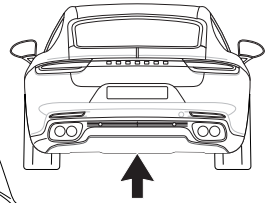
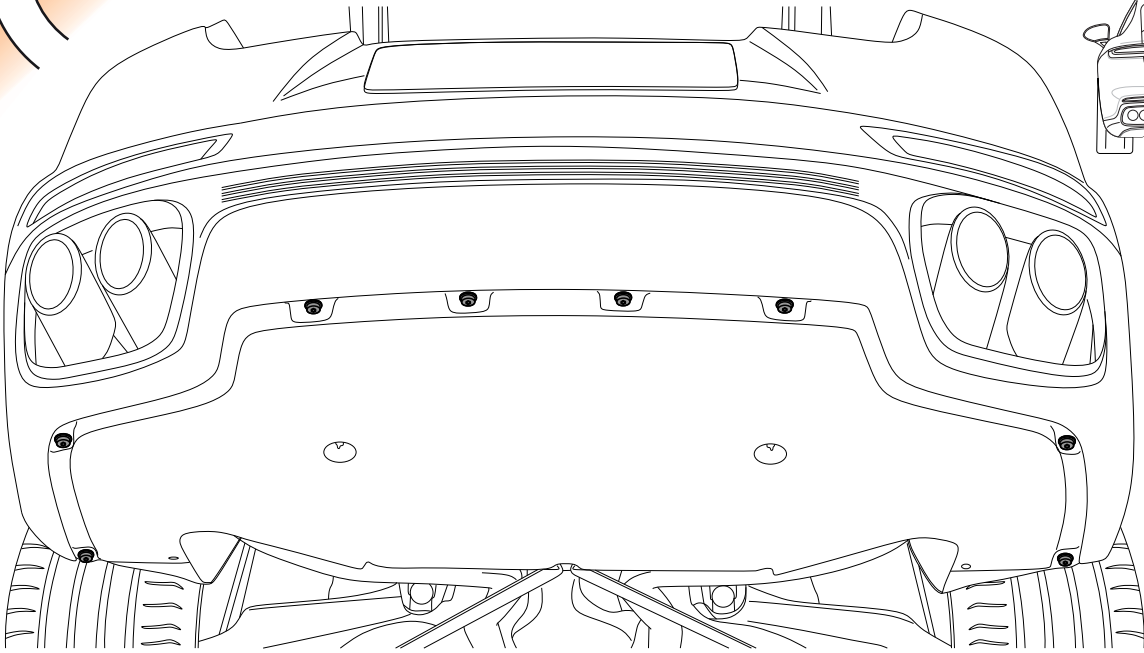

8x

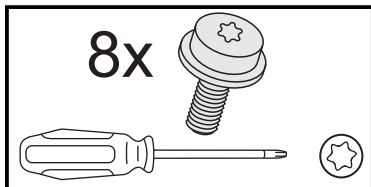

3

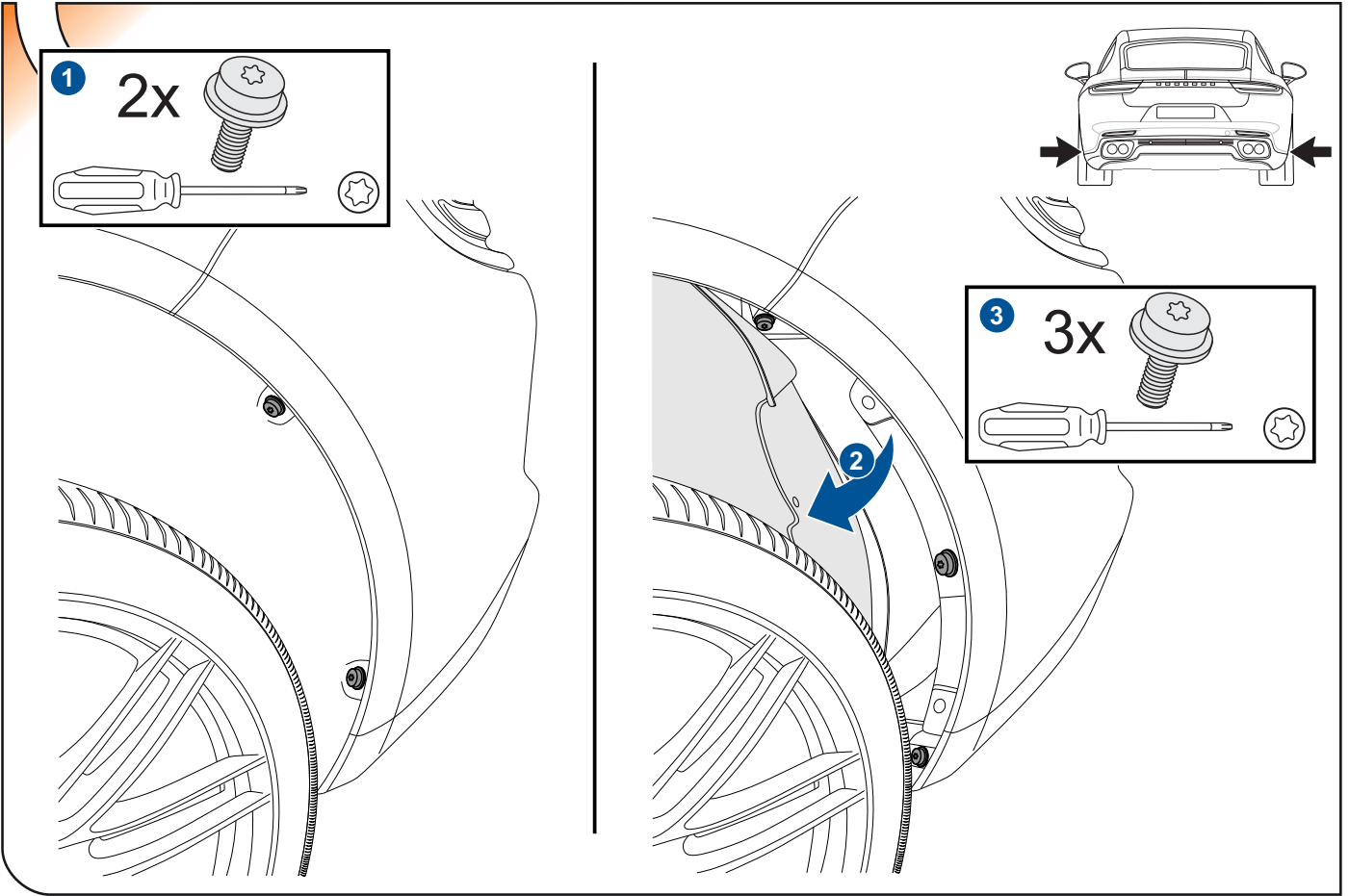

4

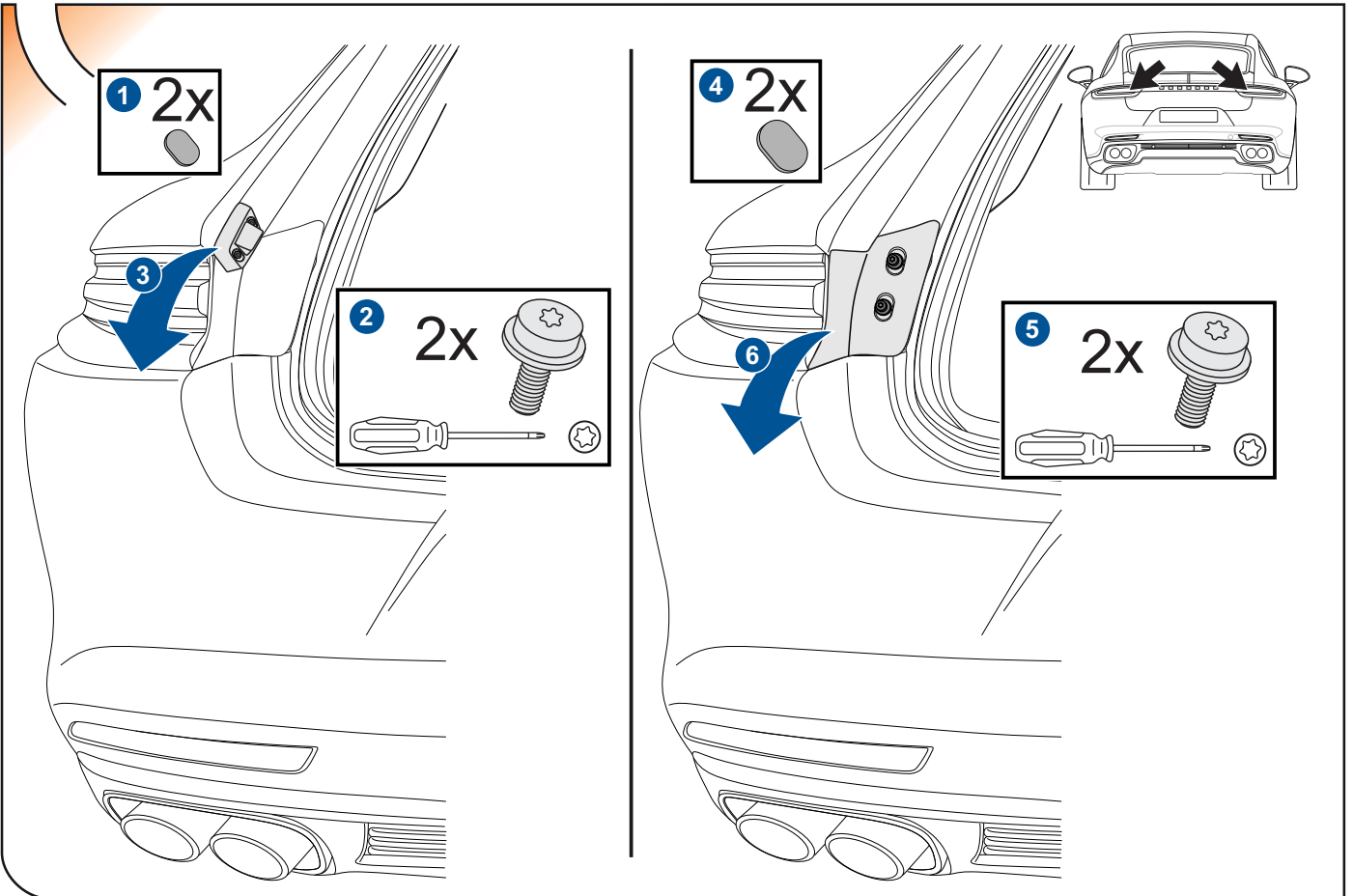

5

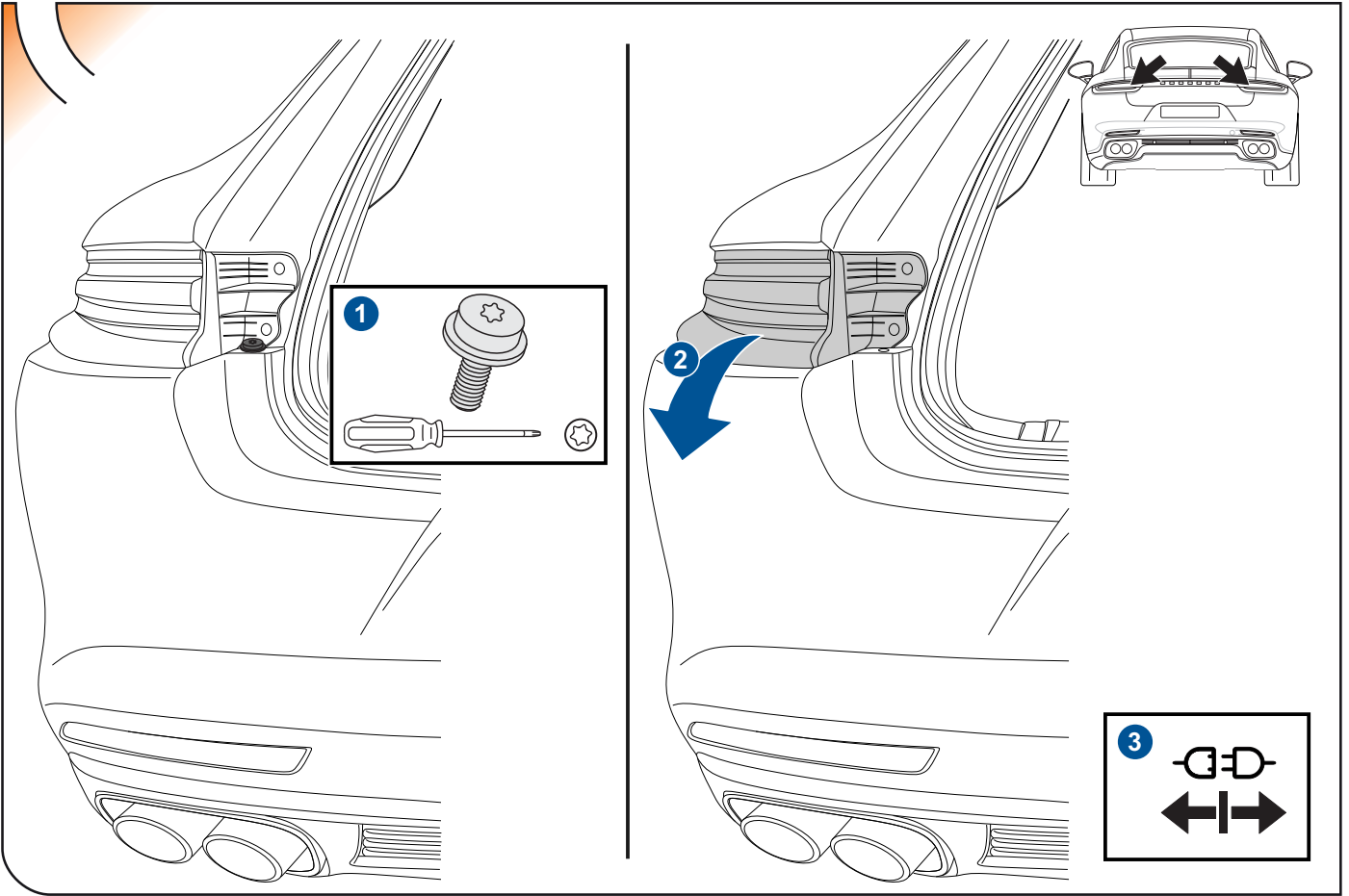

6

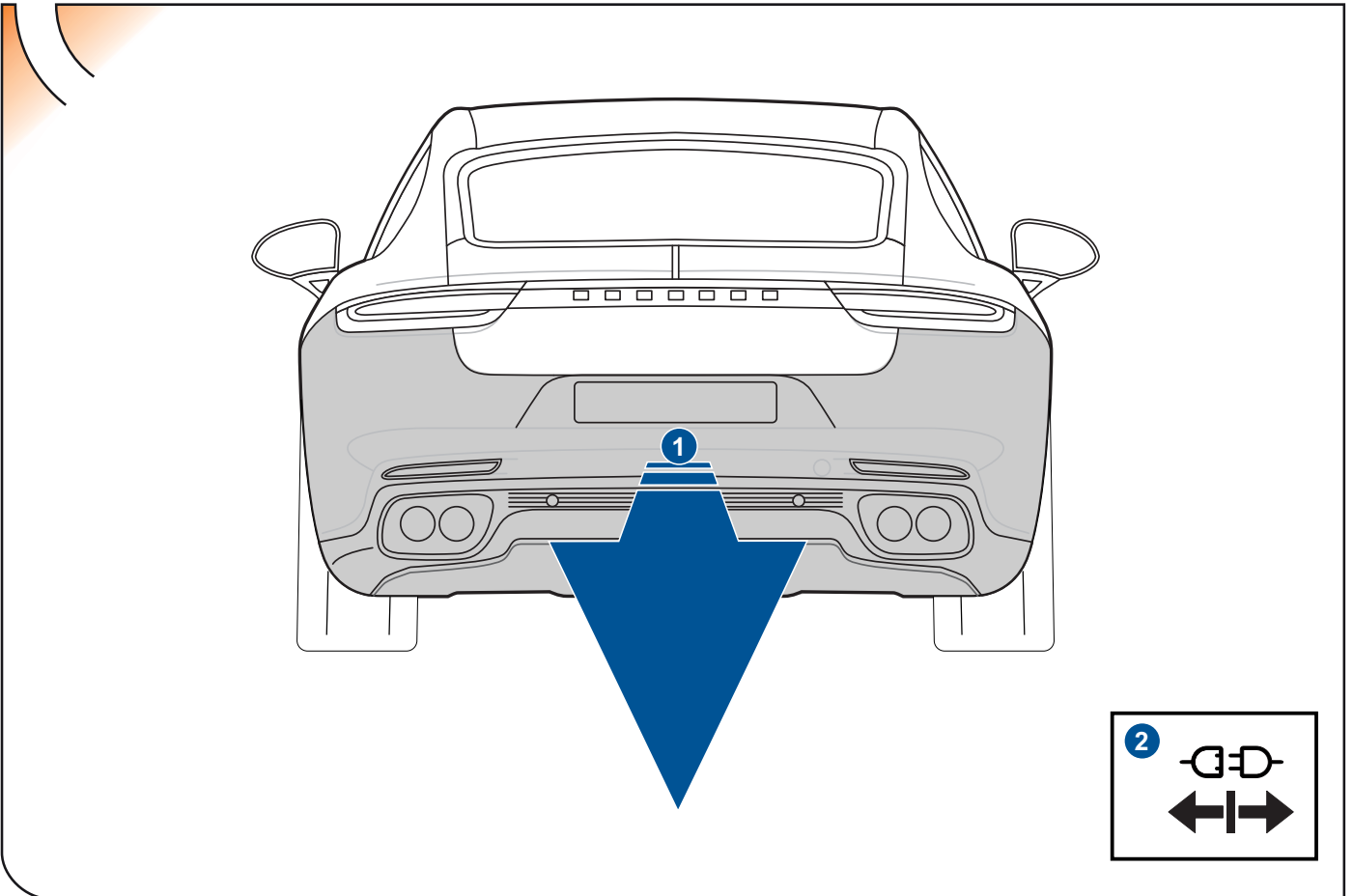

7

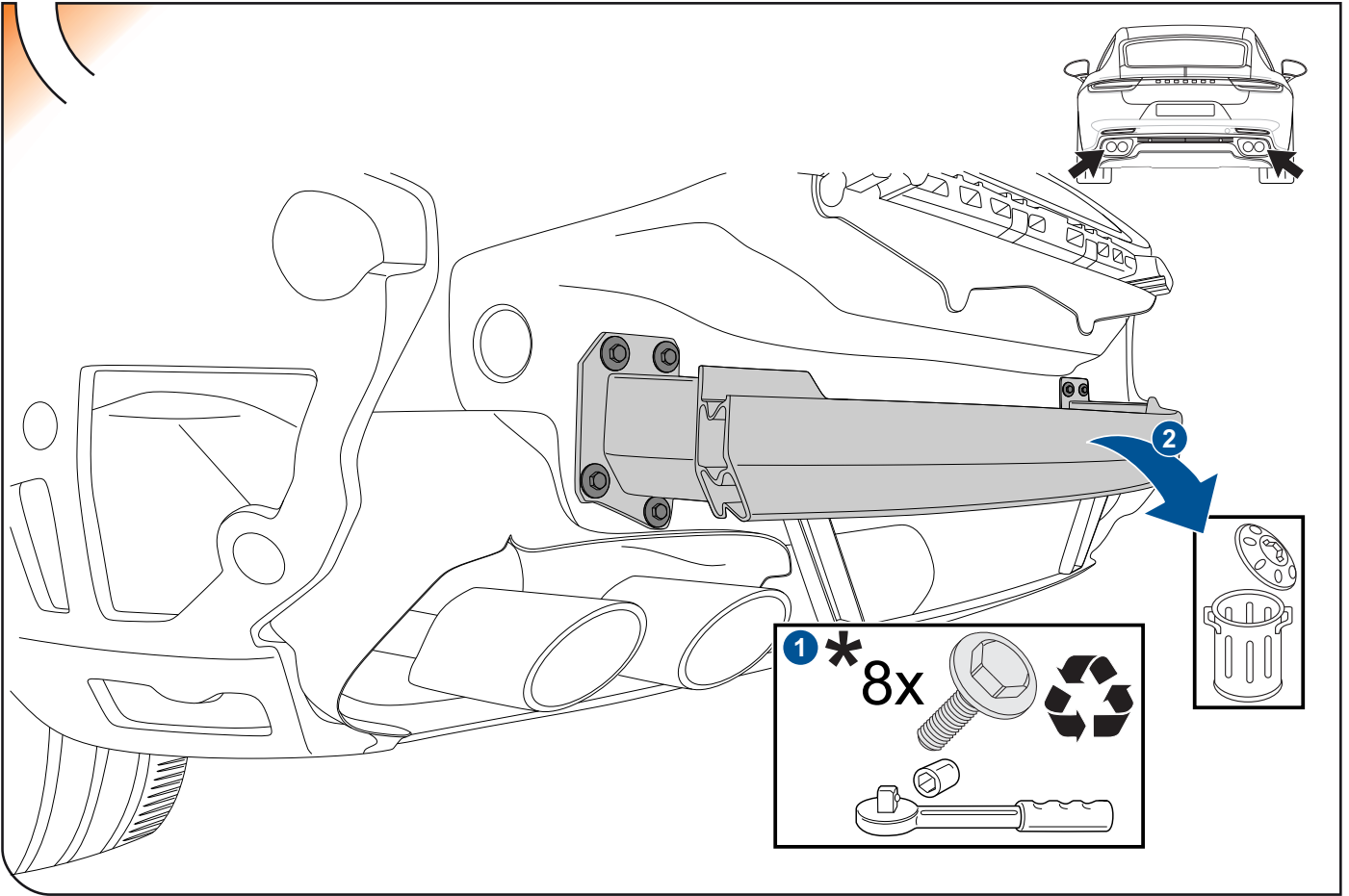

8

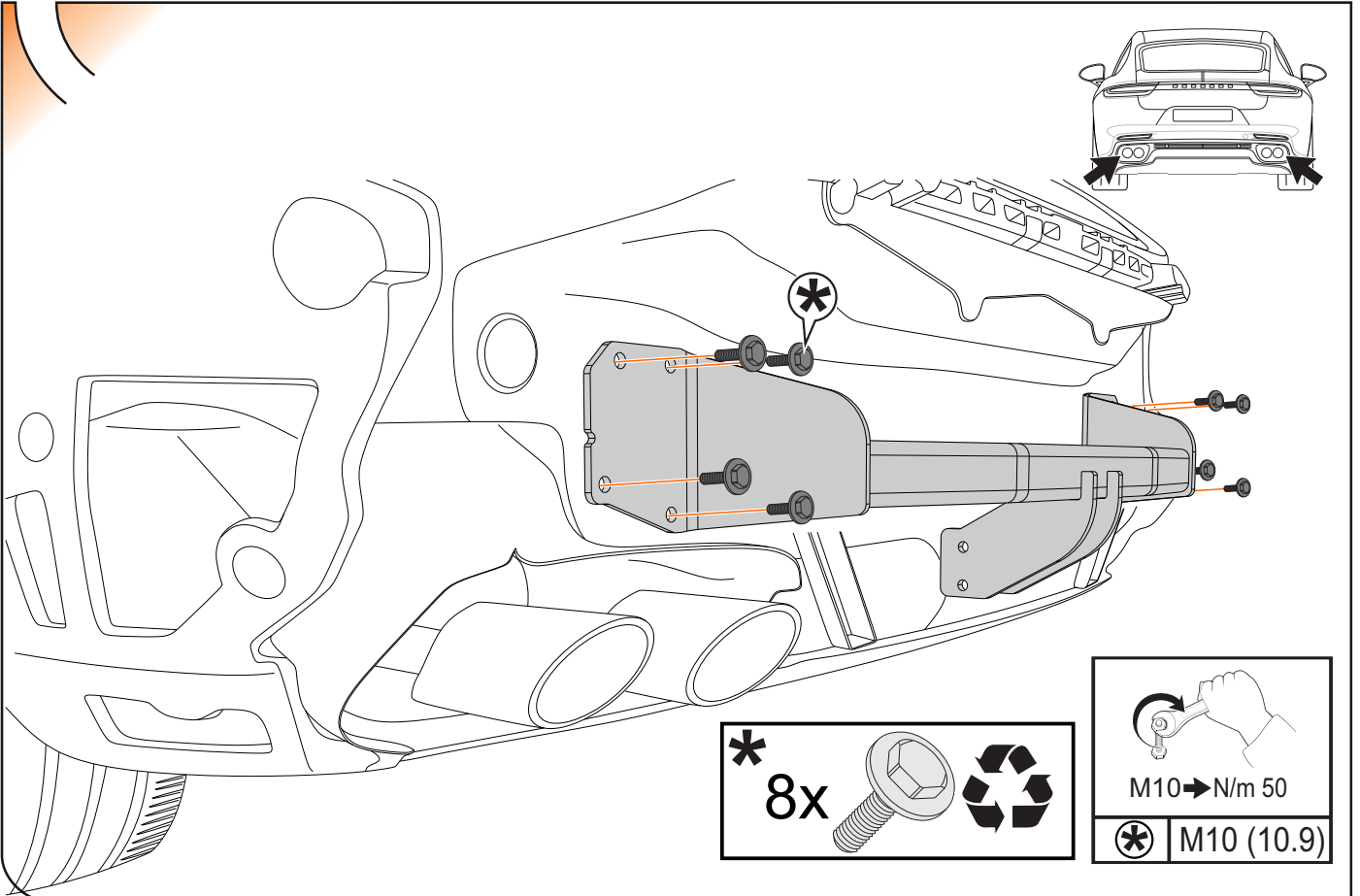

9

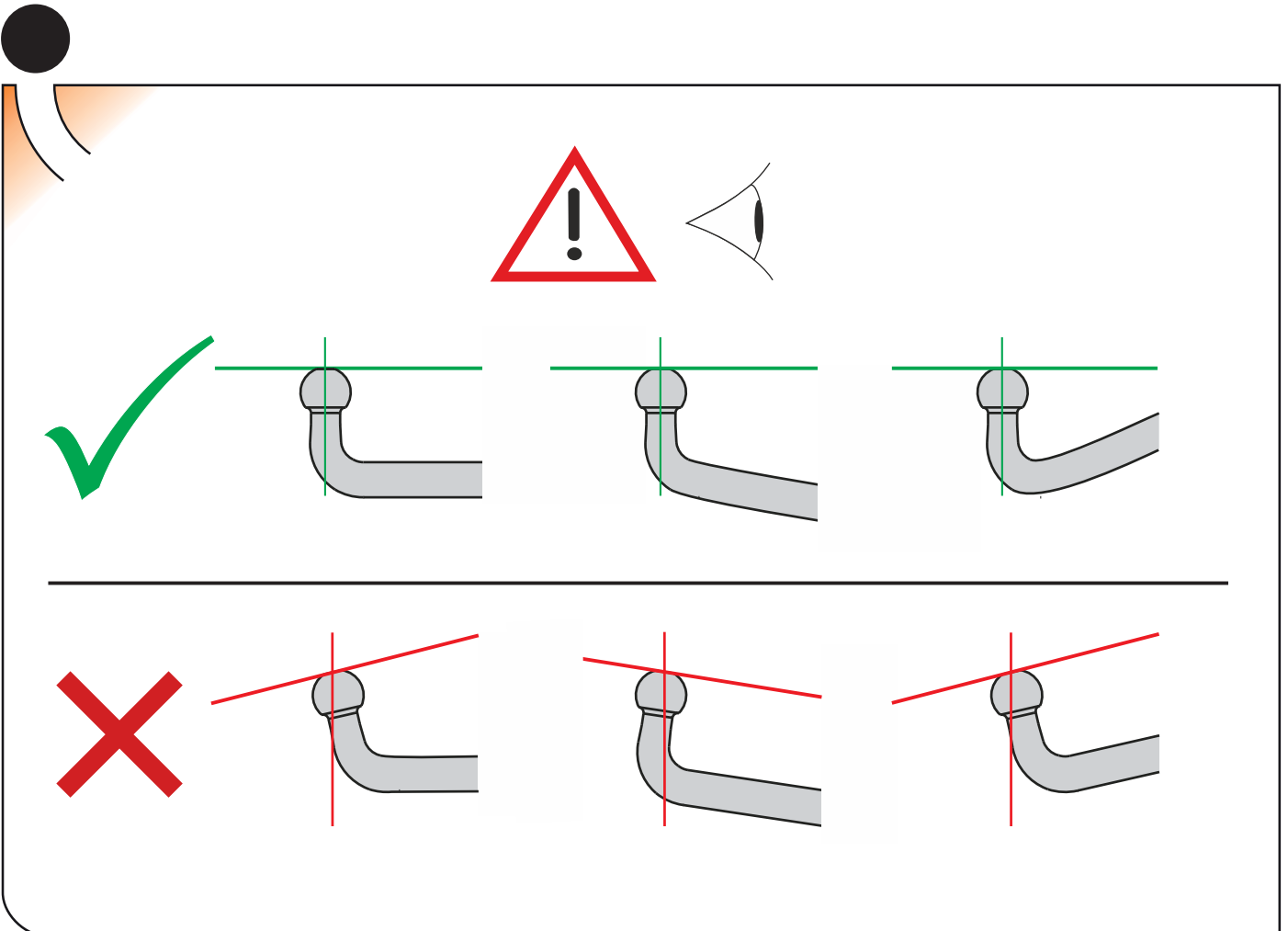
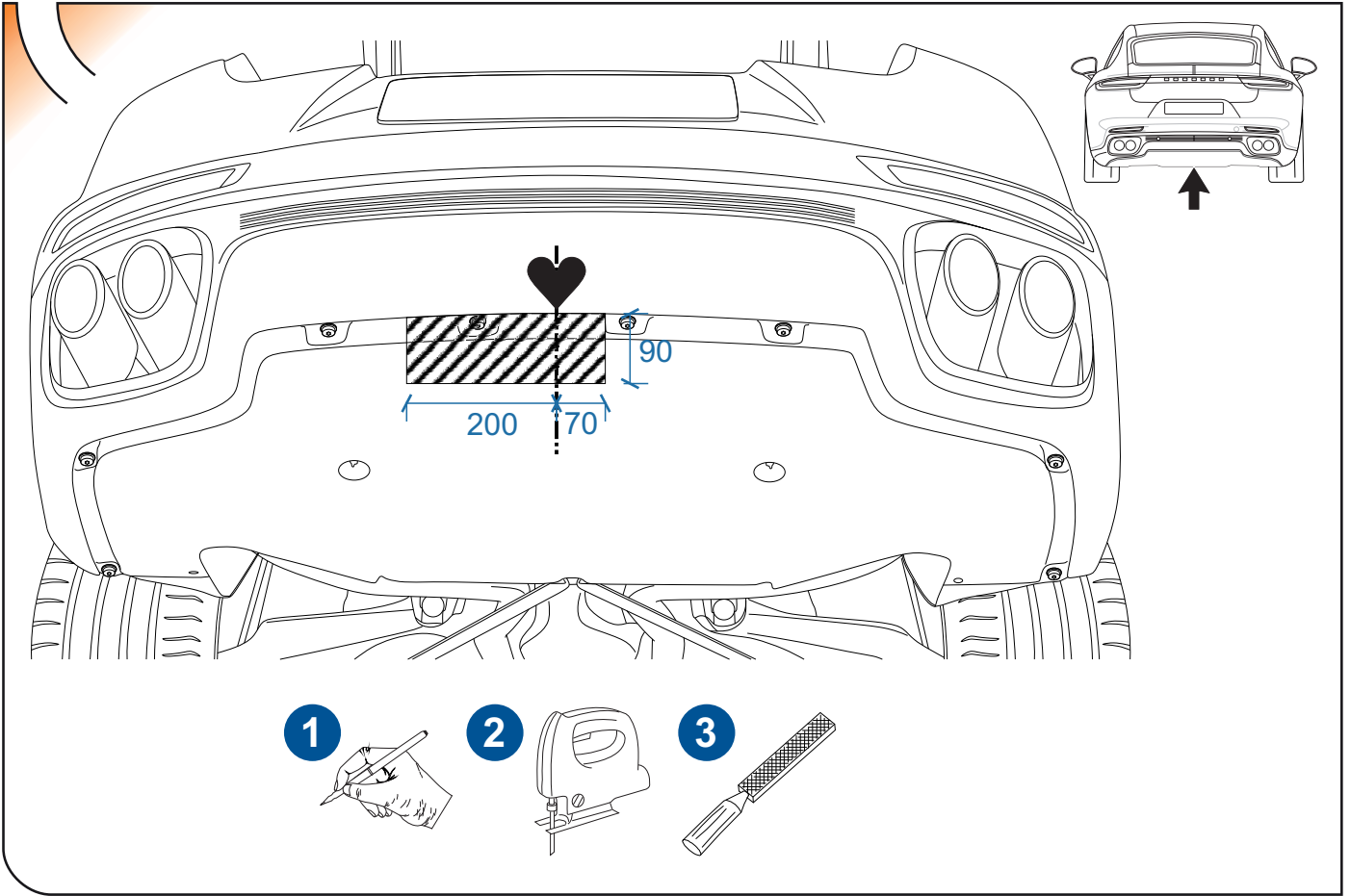

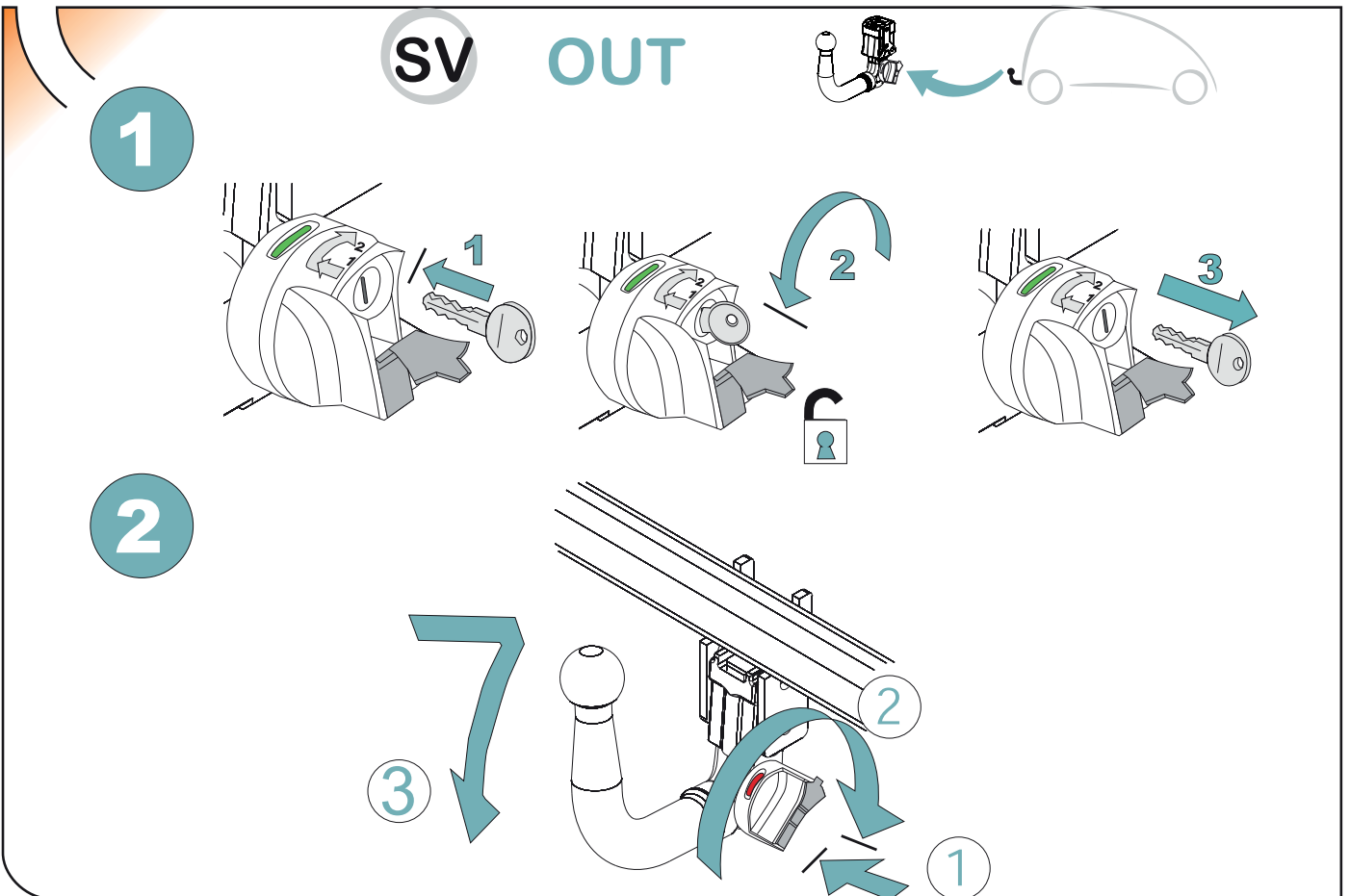
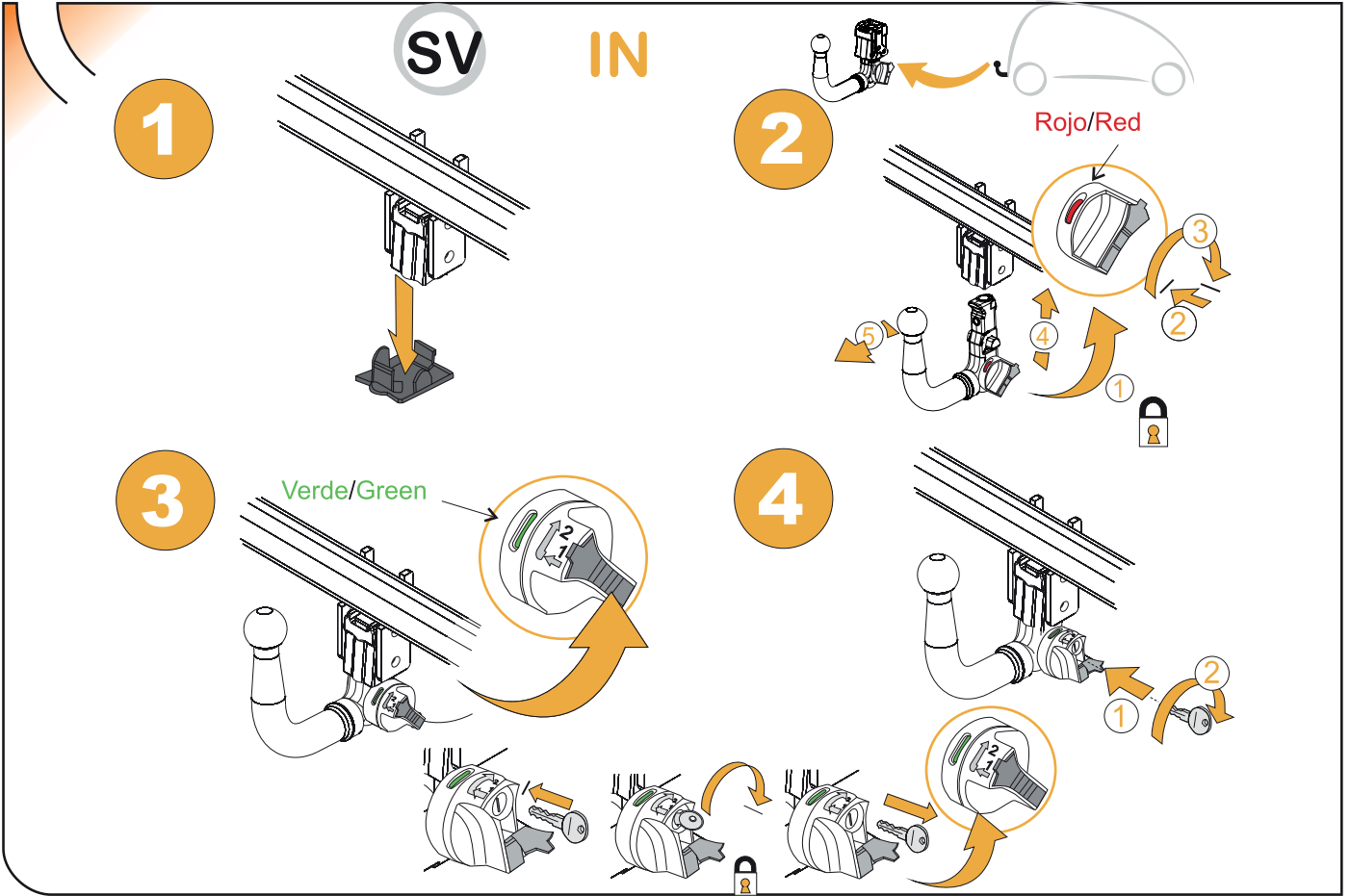

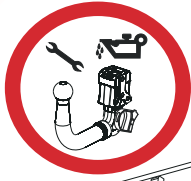

MANTENIMIENTO DE SISTEMAS EXTRAIBLES DETACHABLE SYSTEMS MAINTENANCE

SV

1

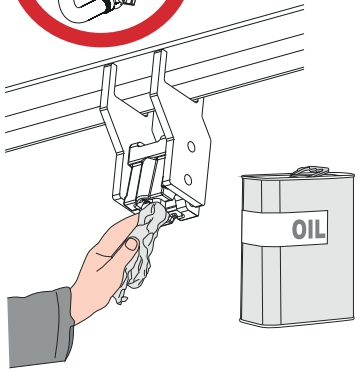

2

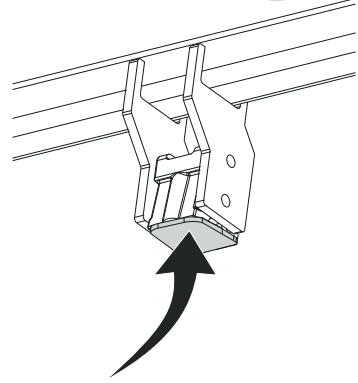

3

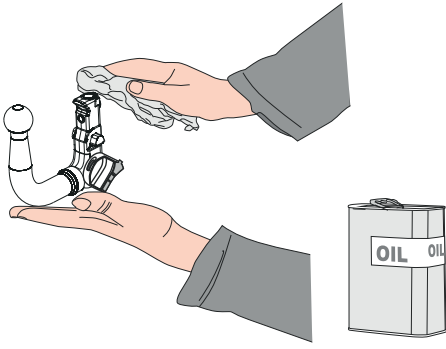

4

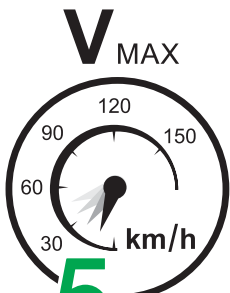
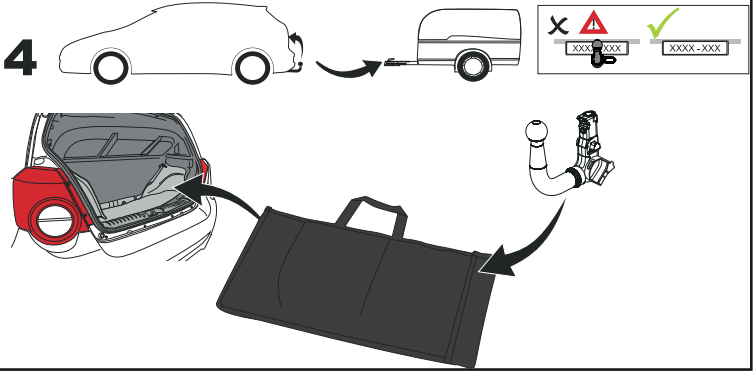

5

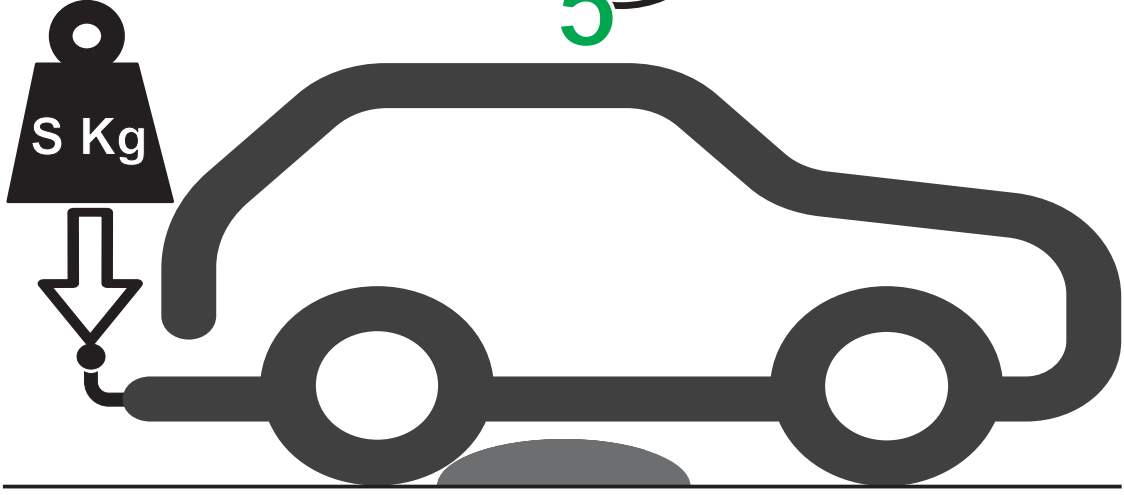

ANEXO III

CERTIFICADO DE TALLER

D. _____, expresamente autorizado por la _____
domiciliada en _____, teléfono _____, dedicada
a la actividad de _____ n° de Registro Industrial _____ y n° de registro
especial _____.

CERTIFICA

Que la mencionada empresa ha realizado la/s Reforma/s y asume la responsabilidad de la ejecución,
sobre el vehículo marca....., tipo.....
variante..... denominación comercial
matrícula y n° de bastidor, de acuerdo con:

- La normativa vigente en materia de reformas de vehículos.
- Las normas del fabricante del vehículo aplicables a la/s reforma/s llevadas a cabo en dicho vehículo.
- El proyecto descriptivo de la/s reforma/s, adjunto al expediente.

OBSERVACIONES: (2)

Tipificada/s con el código de reforma/s.....
Reforma consiste en:

COLOCACION DE ENGANCHE _____

n° de identificación / marca de homologación

Type :

Fecha:

Firma y sello:

Fdo:

(1) En el caso de que la reforma sea efectuada por el fabricante se indicará N/A.

(2) Se debe especificar en este apartado OBSERVACIONES, la identificación de los equipos o sistemas modificados, garantizando que se cumple lo previsto en el artículo 6 del reglamento general de vehículos y, en su caso, en el artículo 5 del R. D. 1457/1986 de 10 de enero, por el que se regula la actividad industrial en talleres de vehículos automóviles, de equipos y sus componentes, modificado por 455/2010 de 16 de abril, por el que se modifica el R. D. 1457/1986 de 10 de enero por el que se regulan la actividad industrial y la prestación.

ES

1

ANEXO III
CERTIFICADO DE TALLER



2

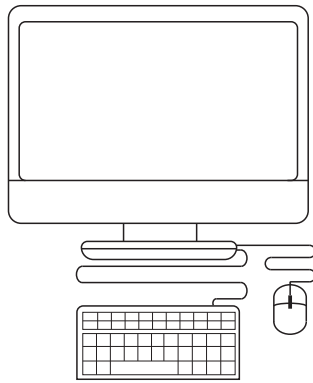

3



IT

1

DICHIARAZIONE DI CORRETTO MONTAGGIO

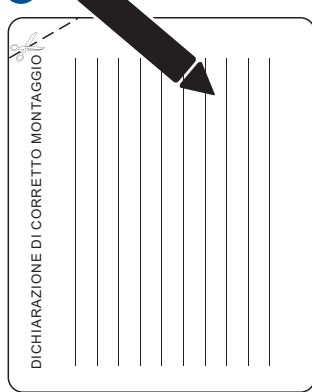

2

