

Mitsubishi Outlander (2012-)
Mitsubishi Outlander PHEV (2012-)

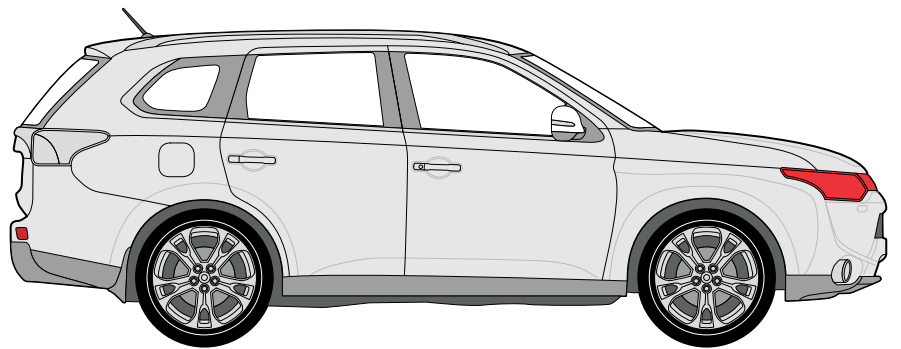

ECE/R55

Mitsubishi Outlander (2012 -)
Mitsubishi Outlander PHEV (2012 -)



E13 APPROVALNUMBER: 55R-01 3602 D-VALUE: 11,07 kN
TYPE: MIT025 CLASS: A50-X MAX.VERT.LOAD: 120 kg

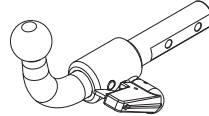

E13 APPROVALNUMBER: 55R-01 3603 D-VALUE: 11,07 kN
TYPE: MIT026-S CLASS: A50-X MAX.VERT.LOAD: 120 kg

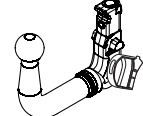

E13 APPROVALNUMBER: 55R-01 3603 D-VALUE: 11,07 kN
TYPE: MIT026-V CLASS: A50-X MAX.VERT.LOAD: 120 kg

D = 11,07 kN



T = 2050 Kg



S = 120 kg

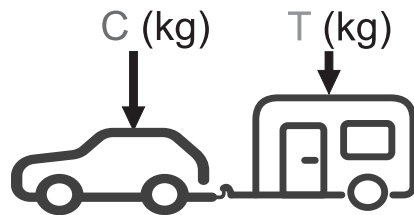
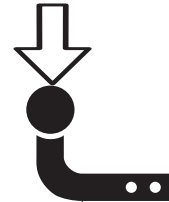

$g = 9,81 \text{ m/s}^2$

$$D \geq \frac{T \cdot C}{T + C} \cdot \frac{g}{1000} \text{ (kN)}$$





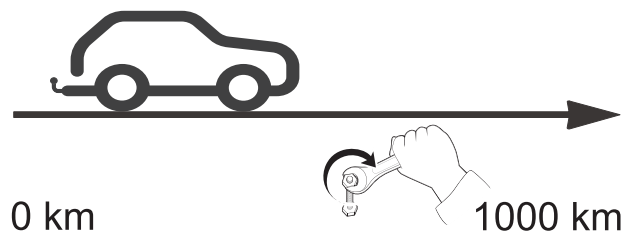

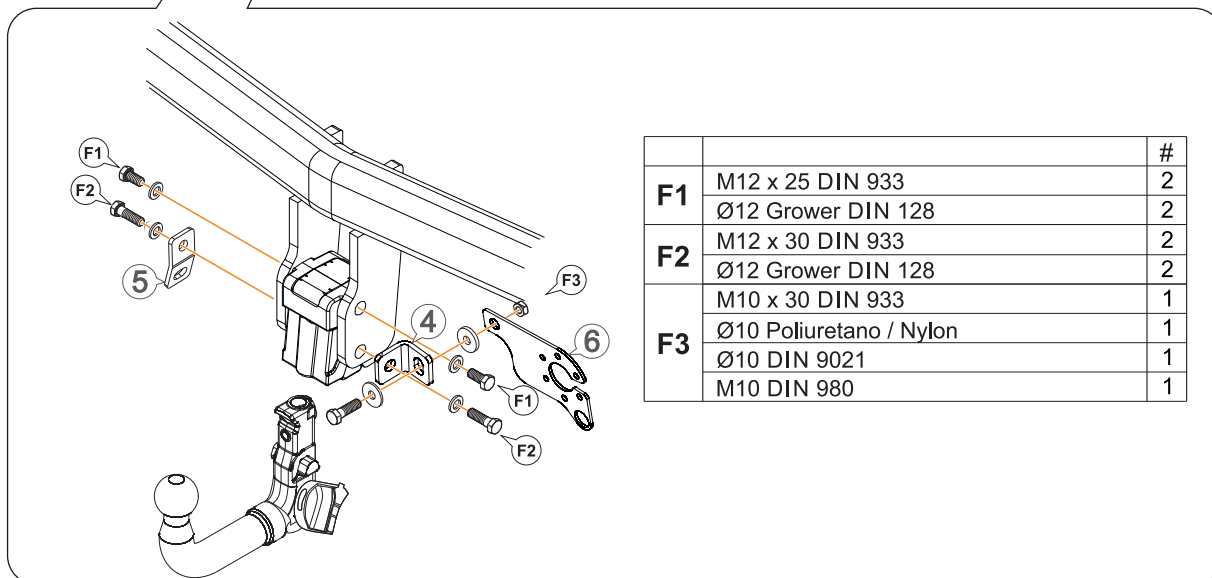
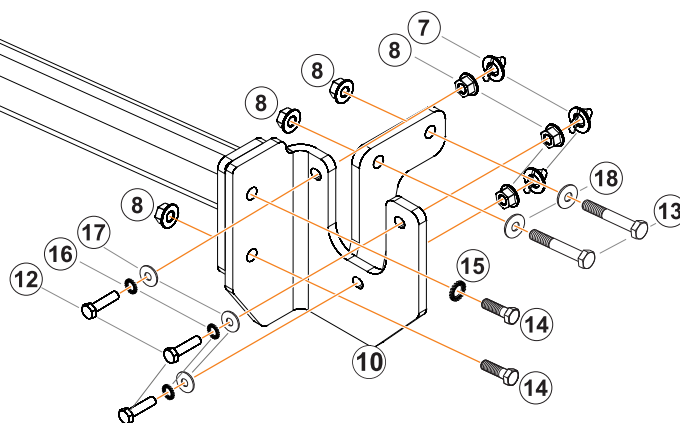
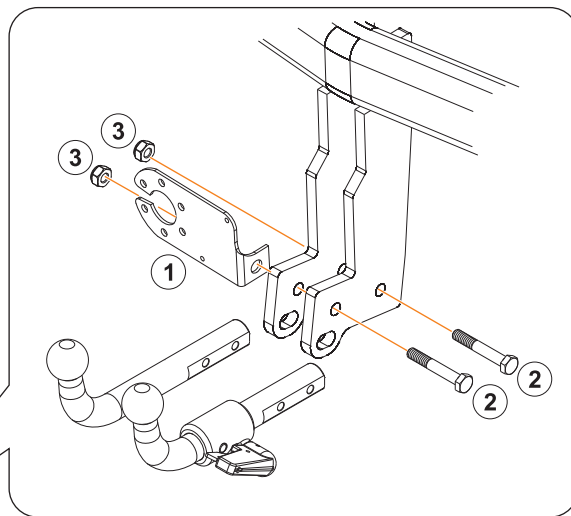
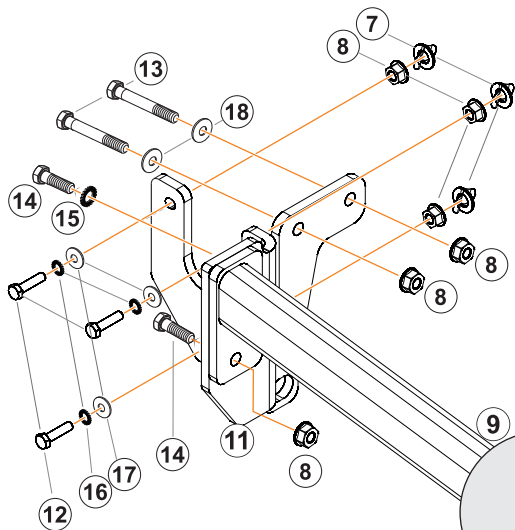



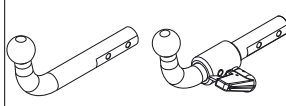
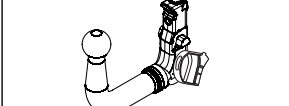







$$T \leq \frac{C \cdot D \cdot 1000}{(C \cdot g) - (1000 \cdot D)} \text{ (kg)}$$

	M8	M10	M12	M14	M16
N/m	20	40	60	105	160





		#
F1	M12 x 25 DIN 933	2
	Ø12 Grower DIN 128	2
F2	M12 x 30 DIN 933	2
	Ø12 Grower DIN 128	2
F3	M10 x 30 DIN 933	1
	Ø10 Poliuretano / Nylon	1
	Ø10 DIN 9021	1
	M10 DIN 980	1

				
1			1	
2		M10x65 DIN 931 (8.8)	2	
3		M10 DIN 980	2	
4		AEV0008		1
5				1
6		AEV0009		1
7			6	6
8		M12 DIN 6923	12	12
9		C4204C	1	1
10		C4204CA22	1	1
11		C4204CA21	1	1
12		M8x40 DIN 933	6	6
13		M12x110 DIN 933 (8.8)	4	4
14		M12x40 DIN 933 (8.8)	4	4
15		Ø12 DIN 6798	2	2
16		Ø8 DIN 6798	6	6
17		Ø8 DIN 9021	6	6
18		Ø12 DIN 9021	4	4

1

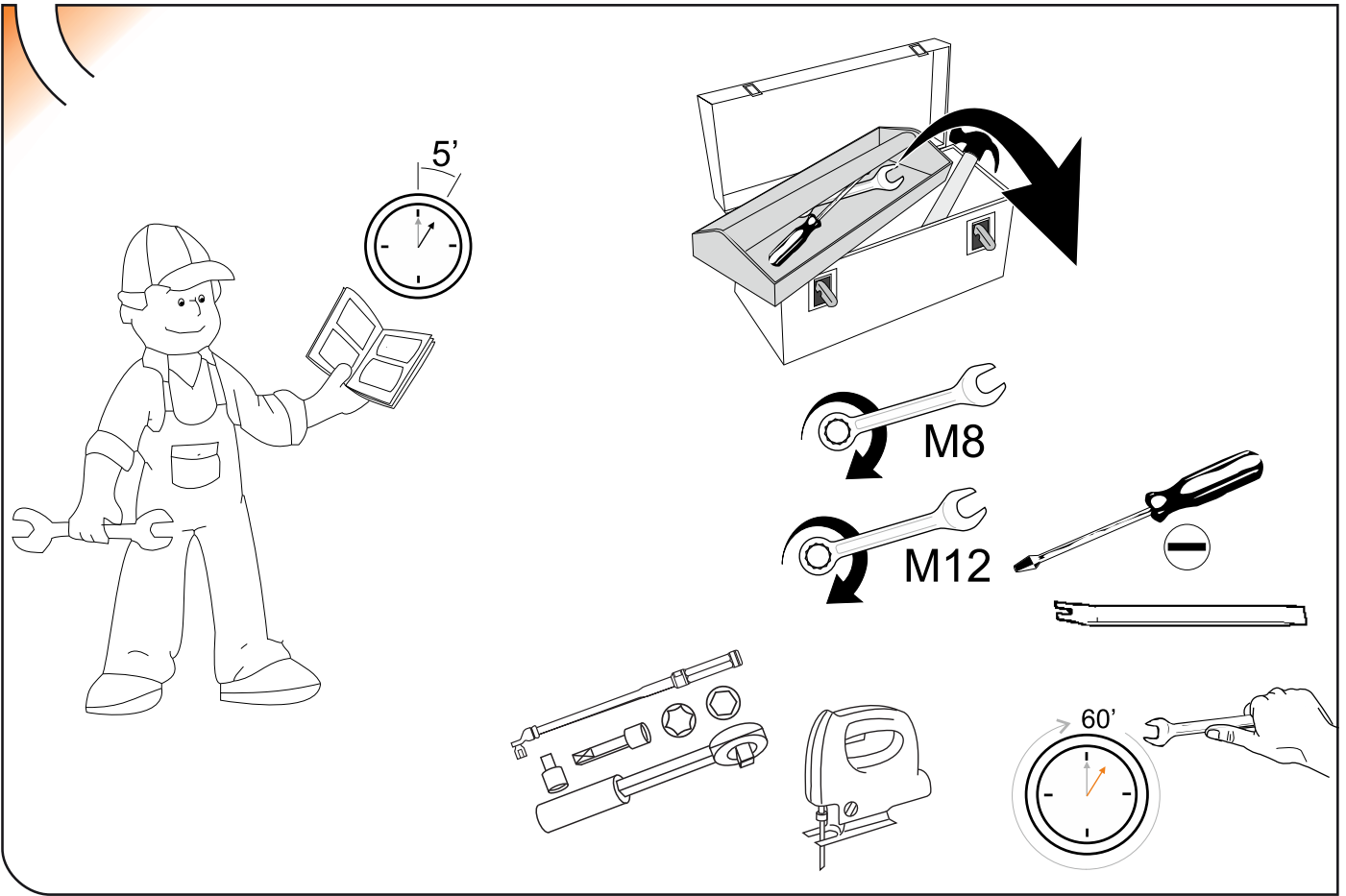

2

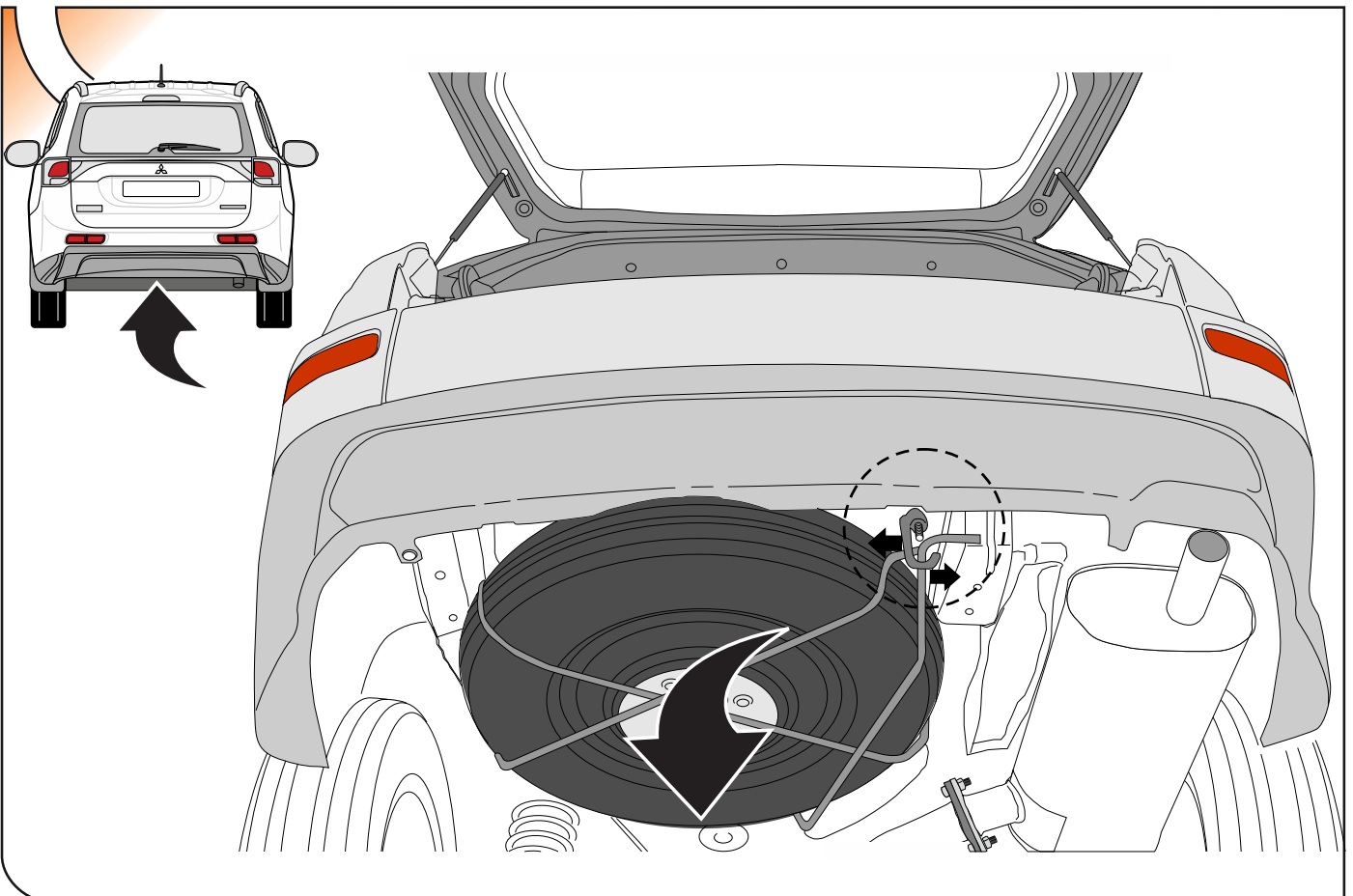

3

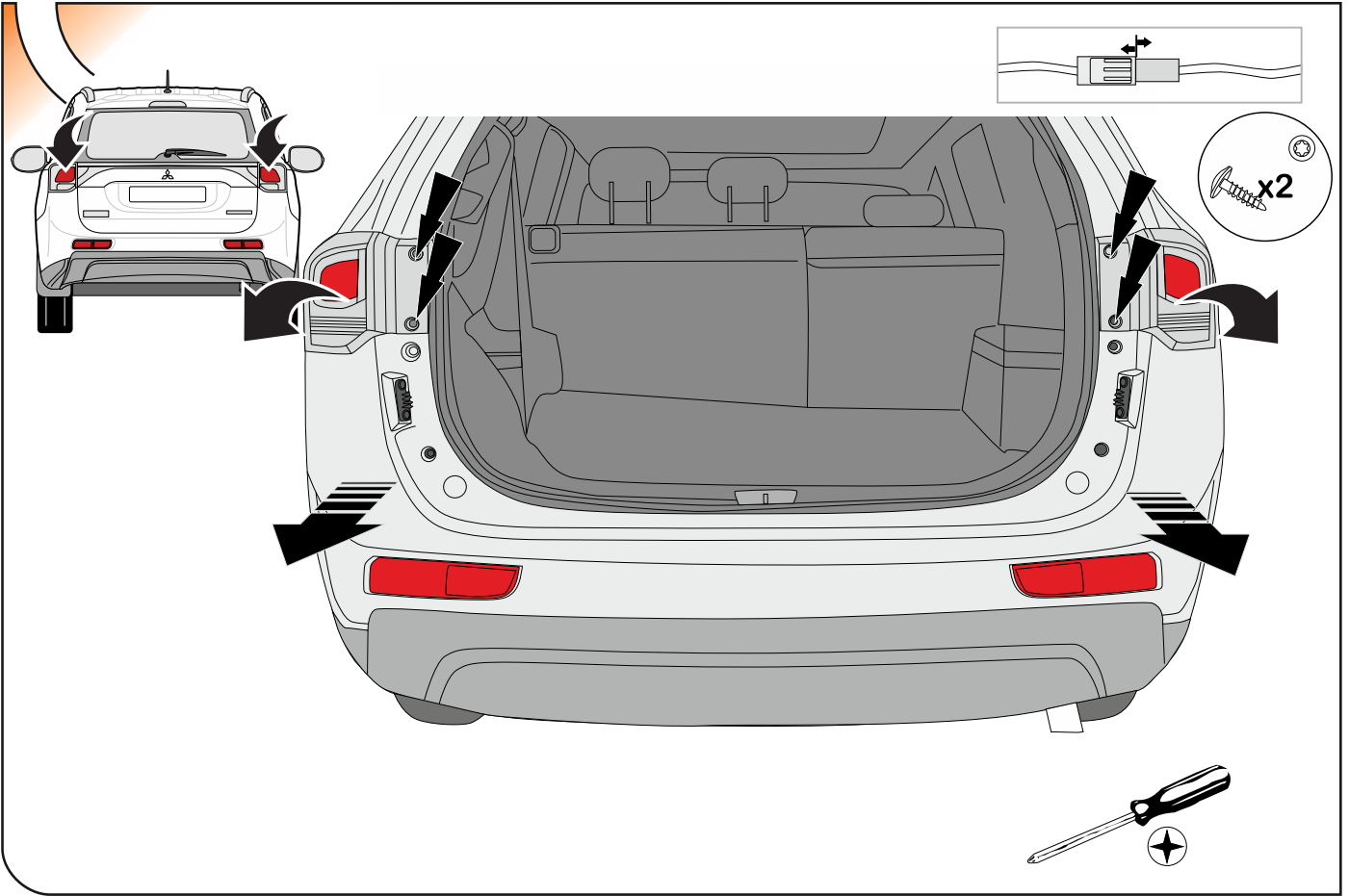

4

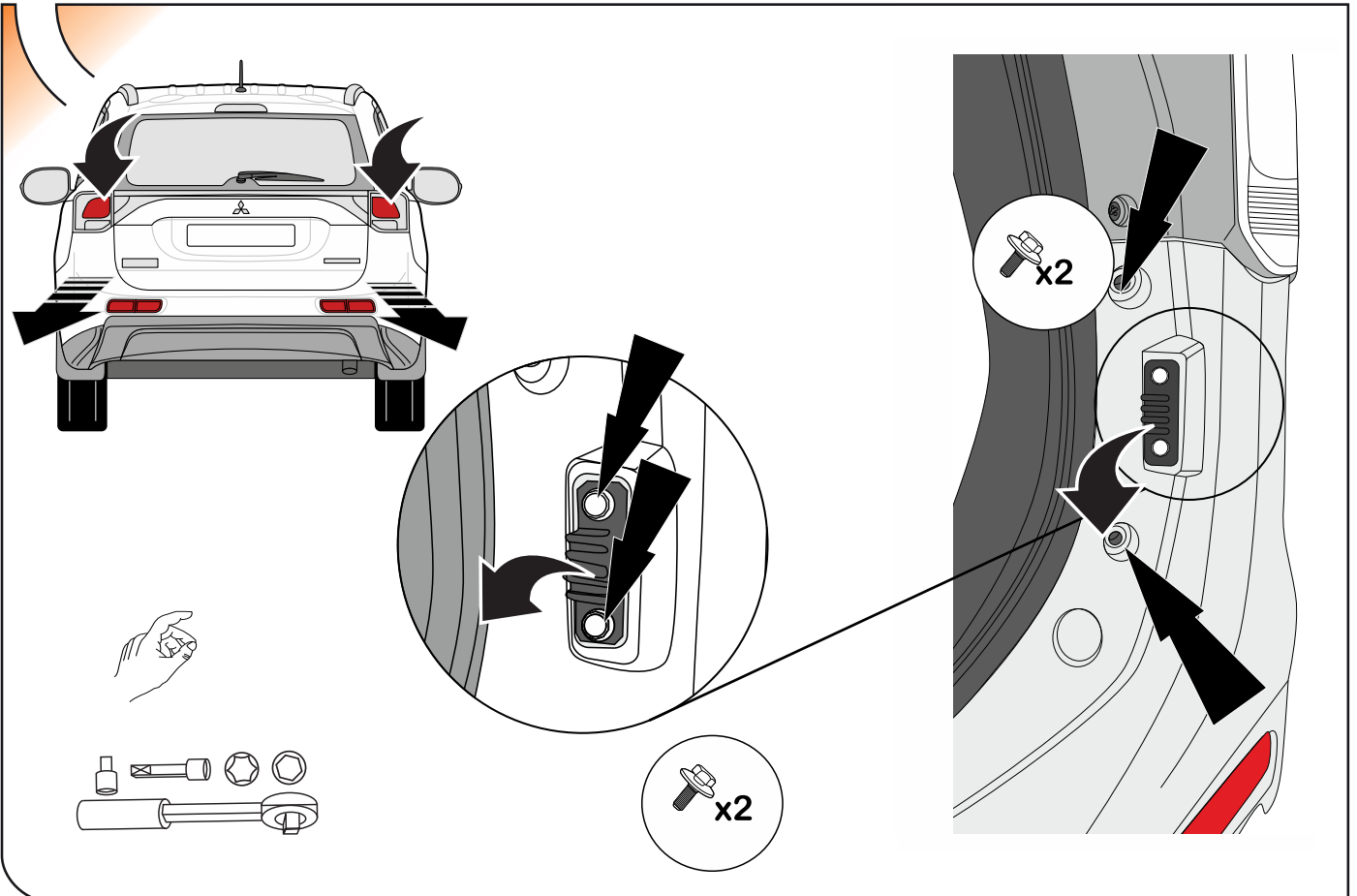

5

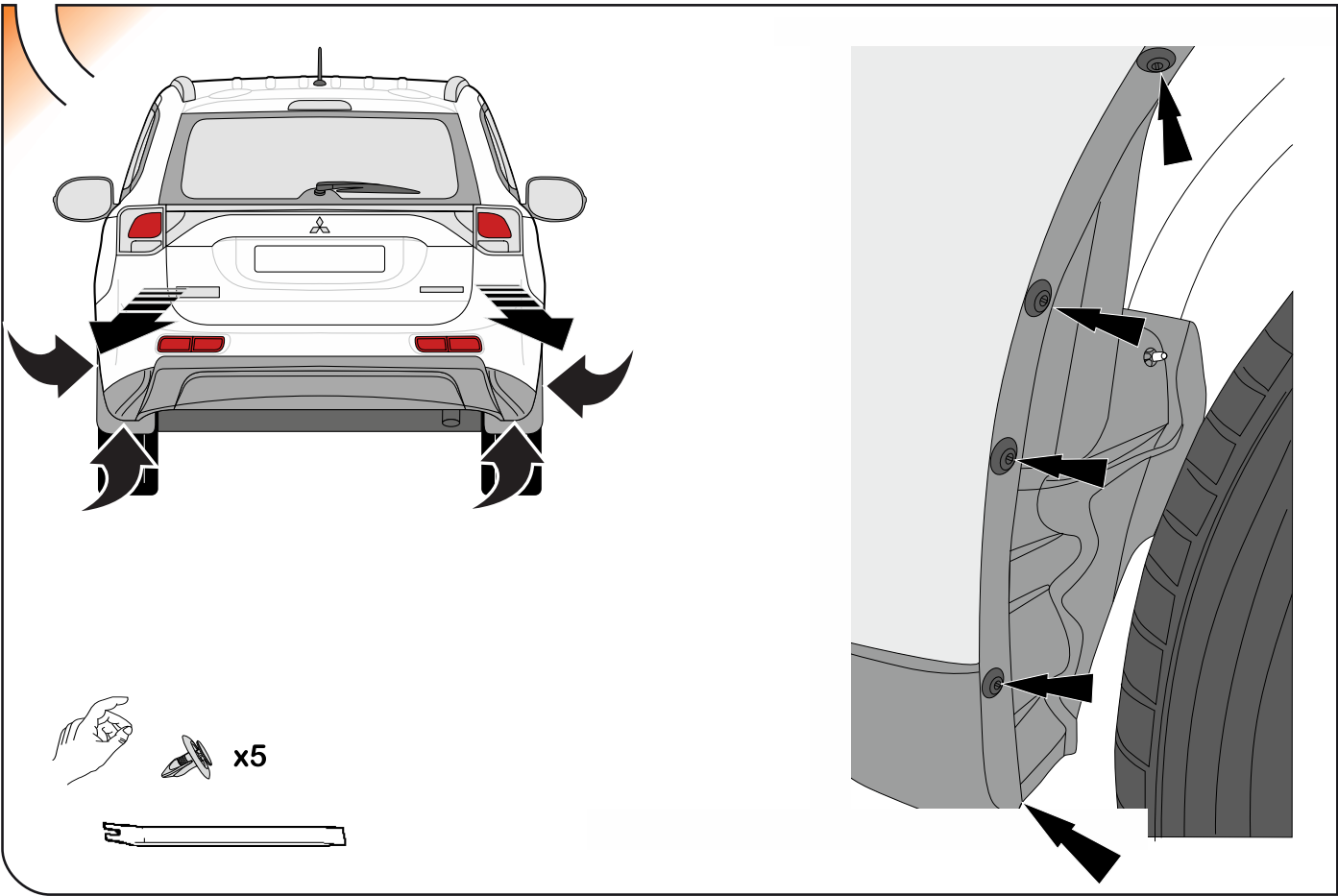

6

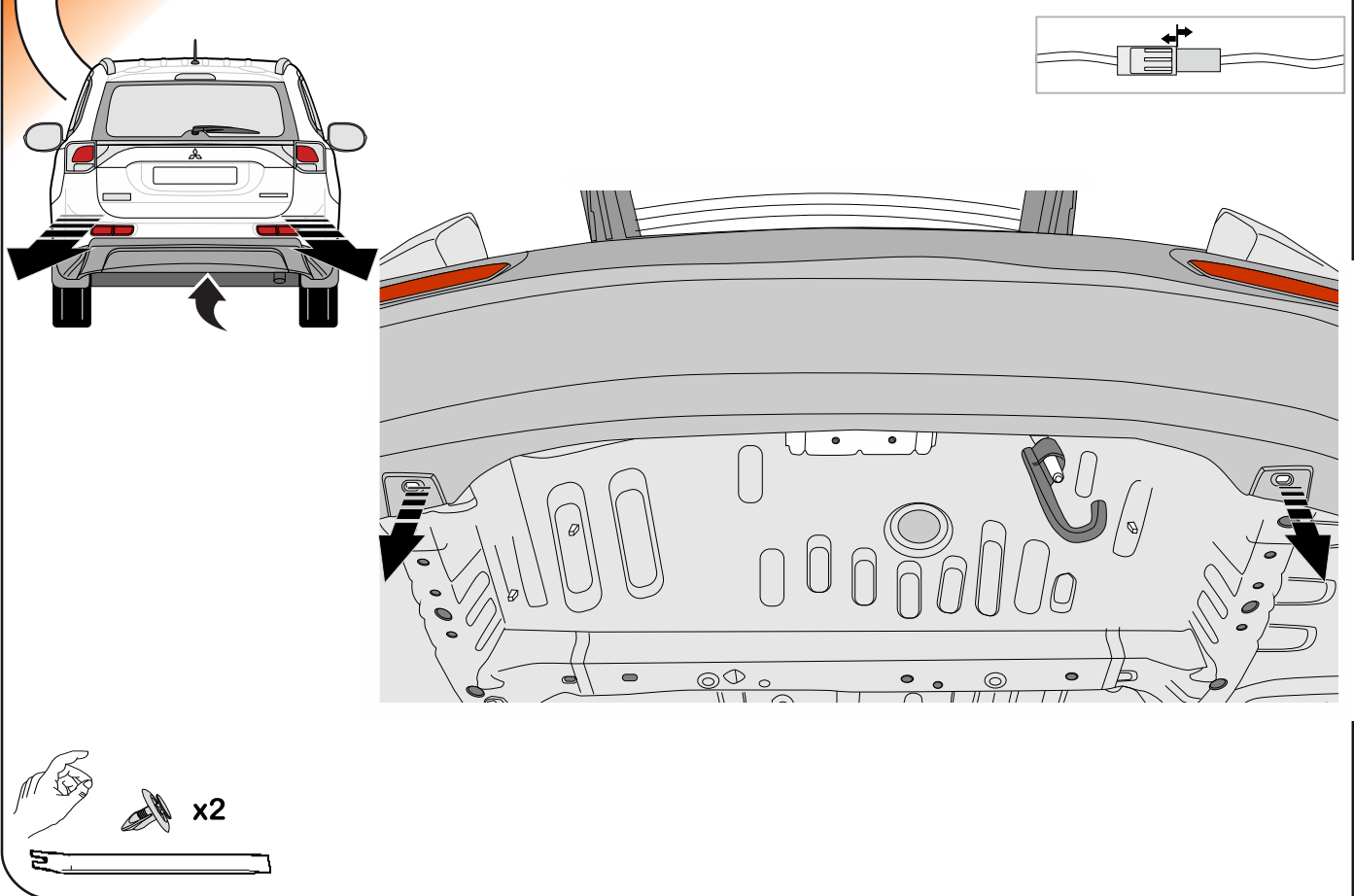

7

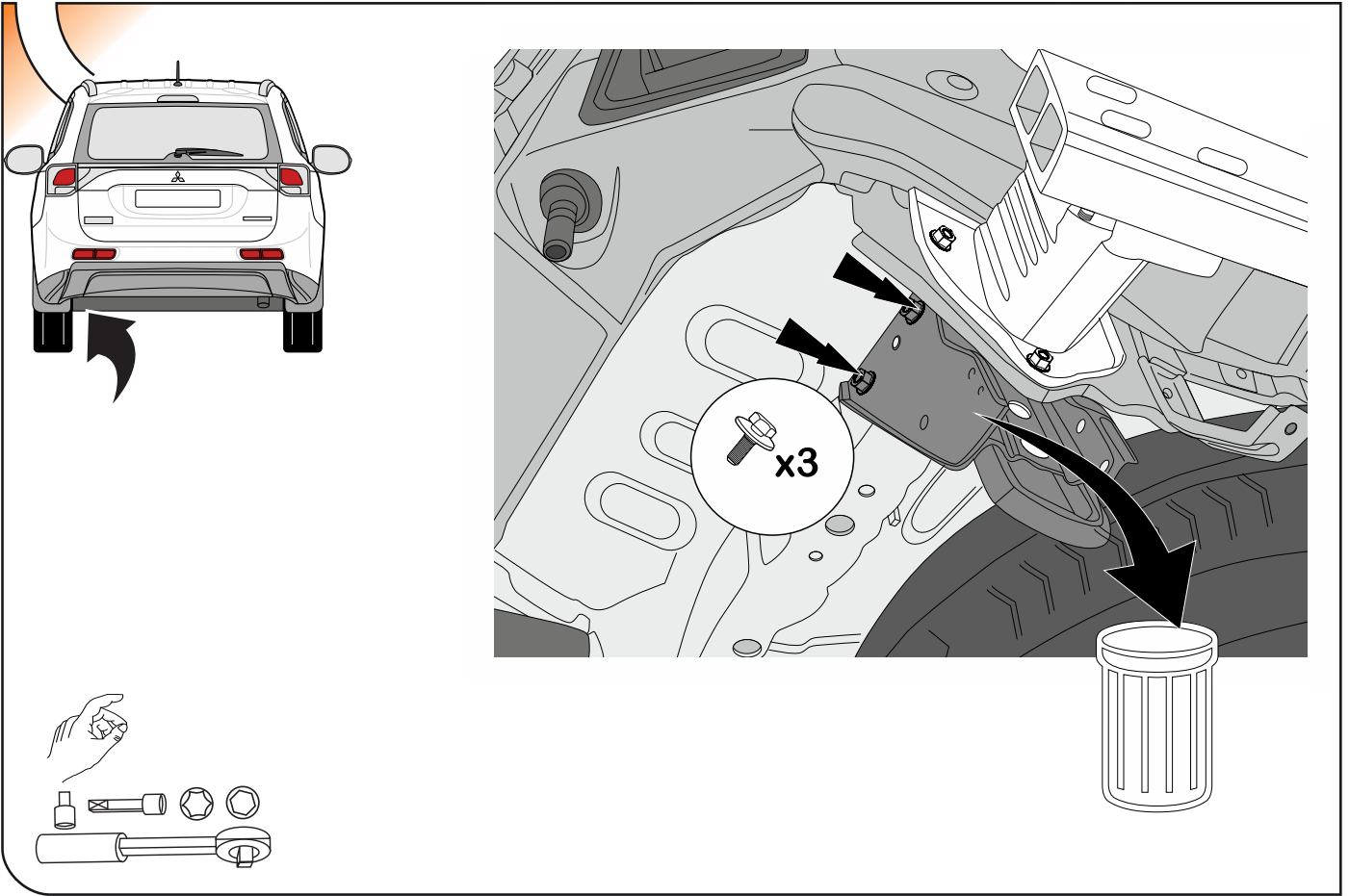

8

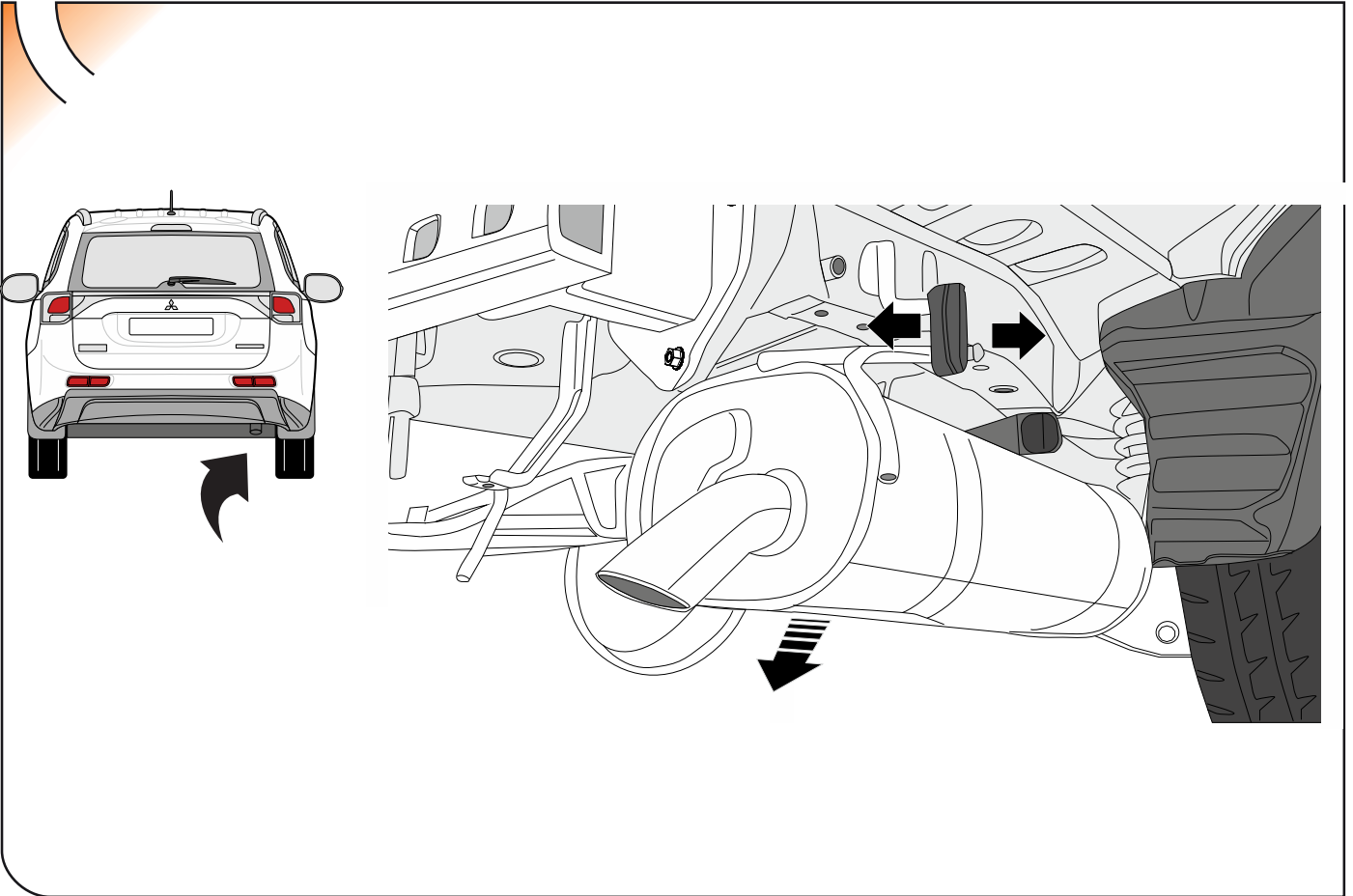

9

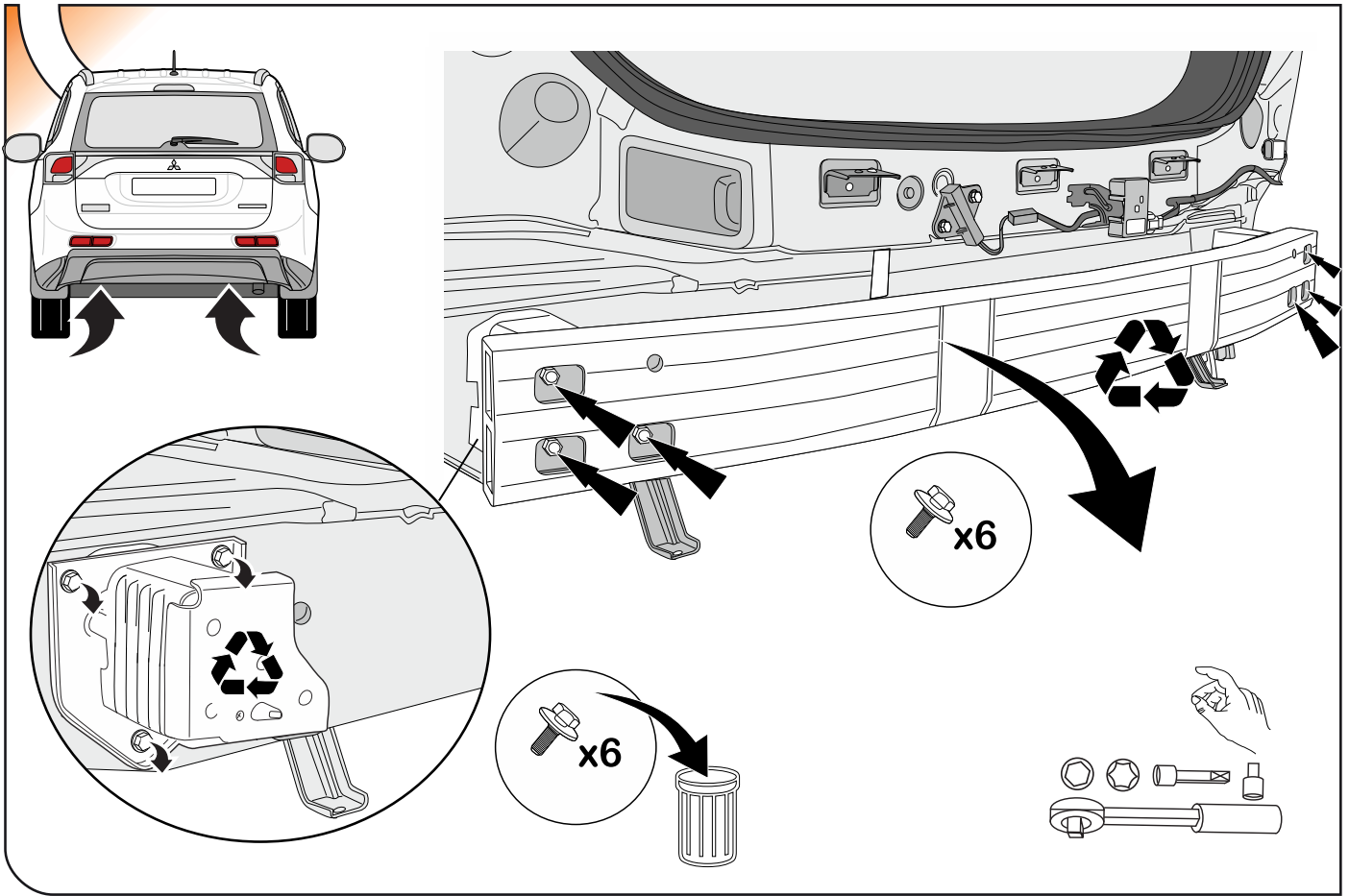

10

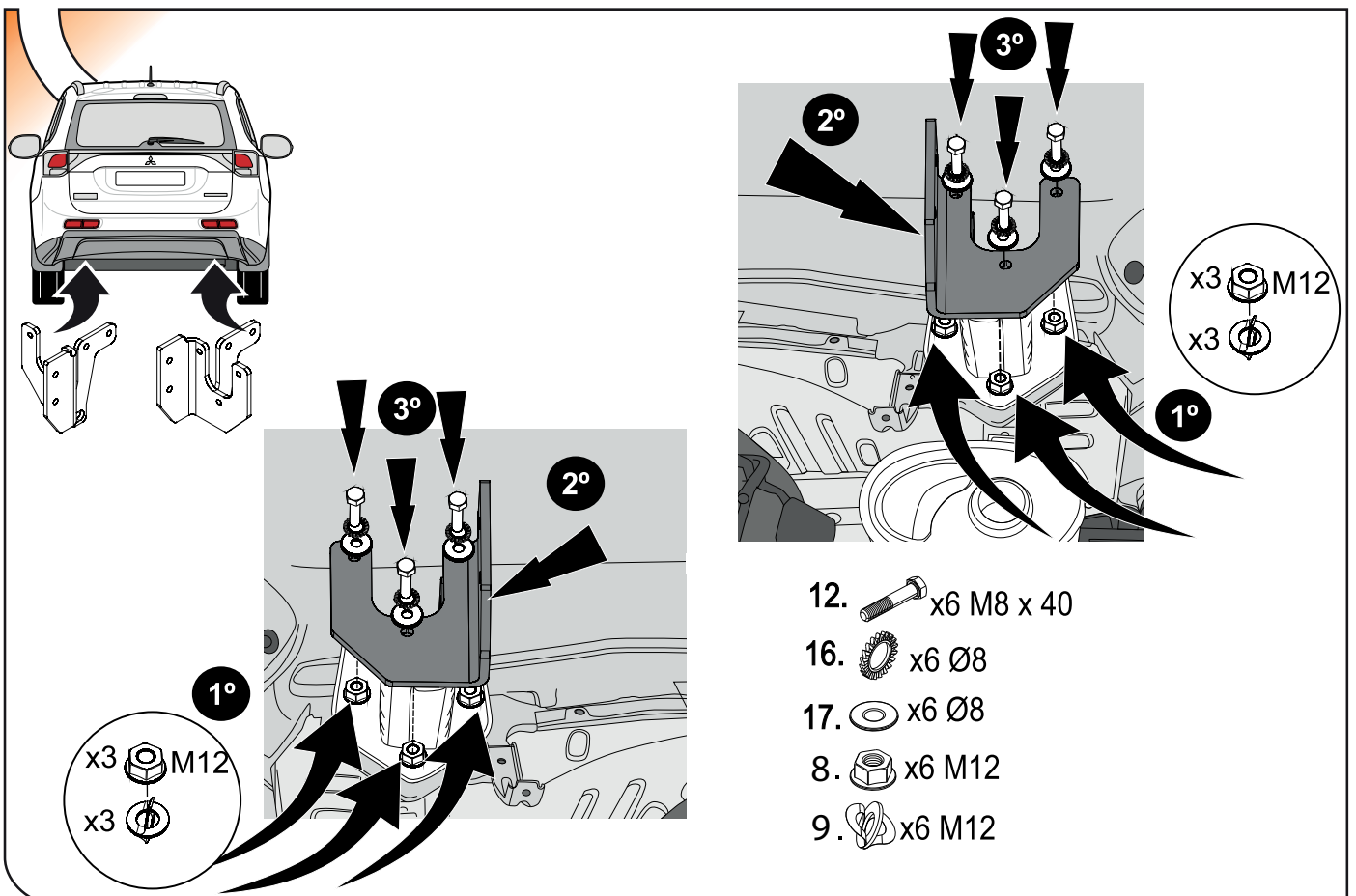

11

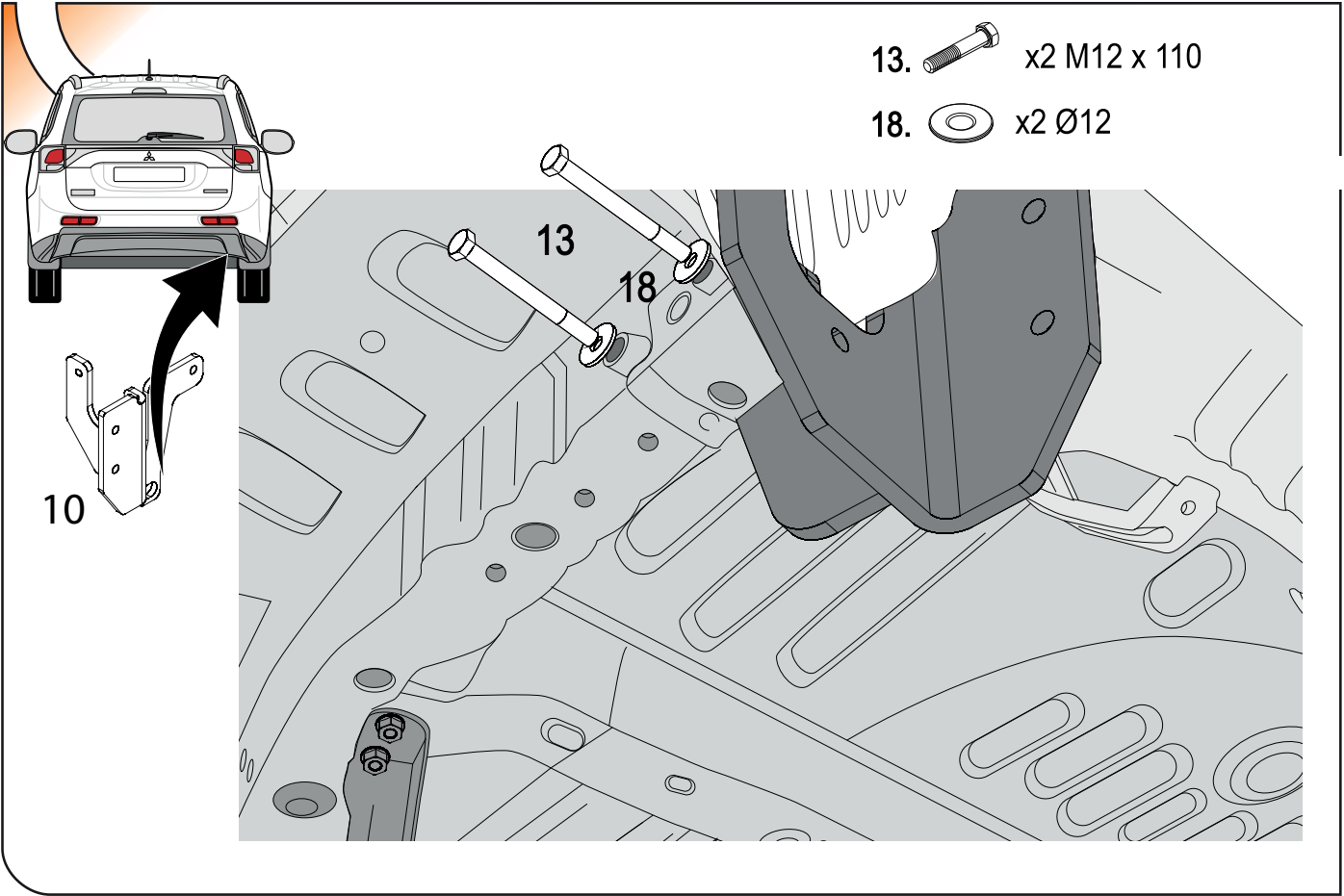

12

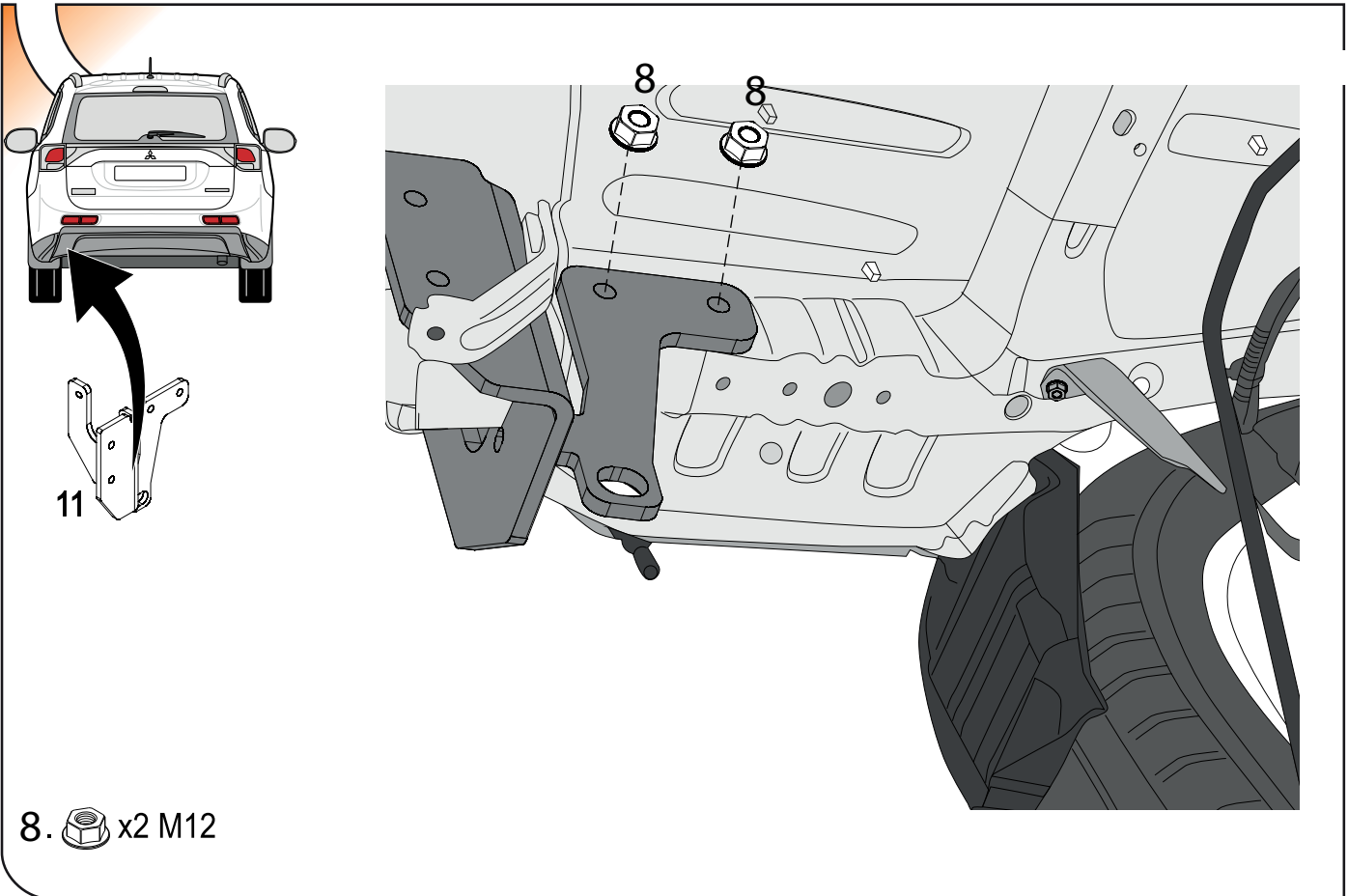

13

13.  x2 M12 x 110

18.  x2 Ø12

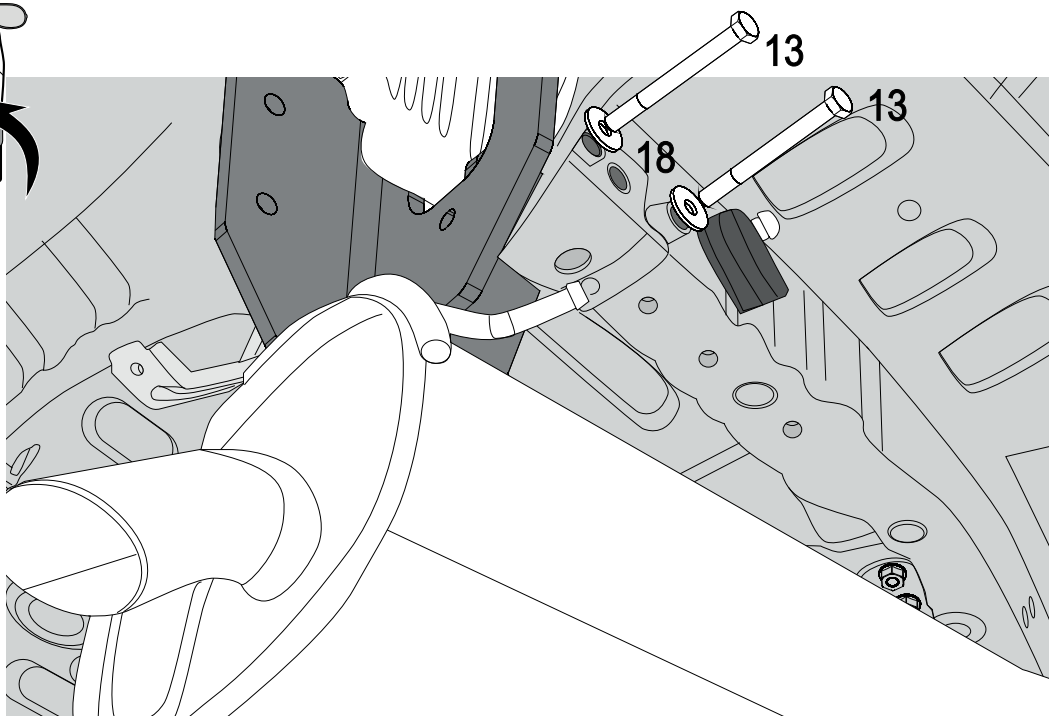
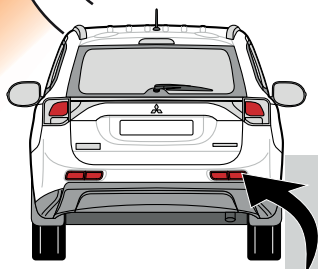

14

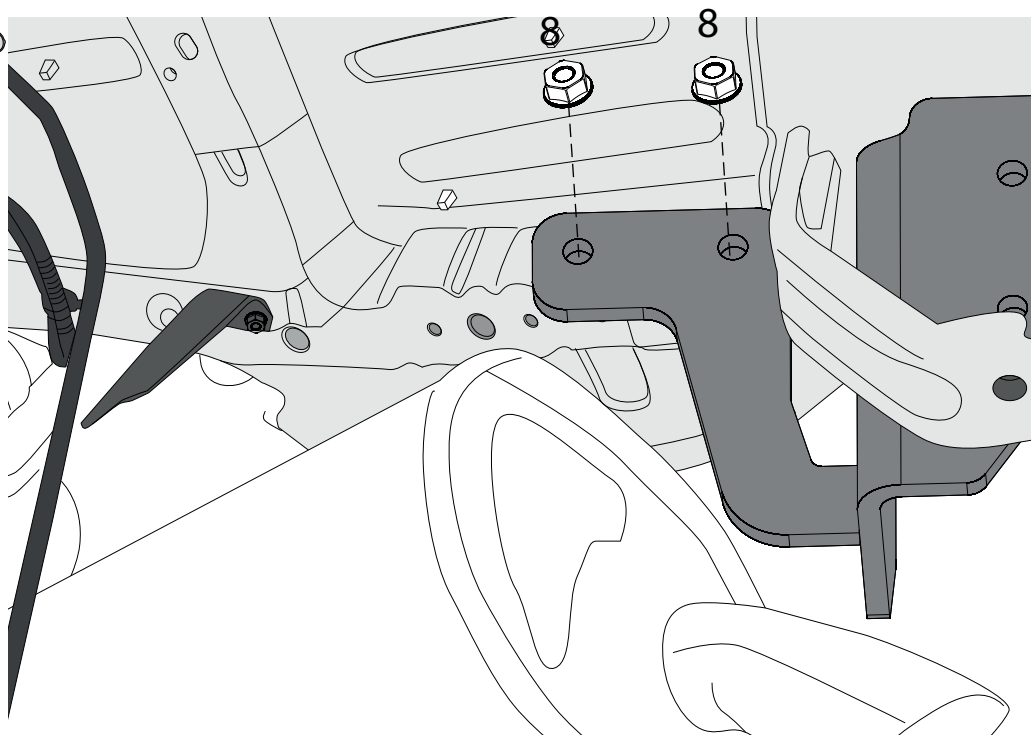
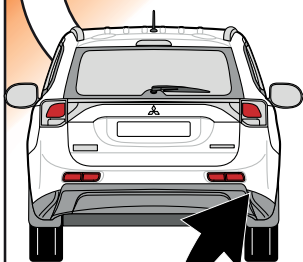

8  x2 M12

15

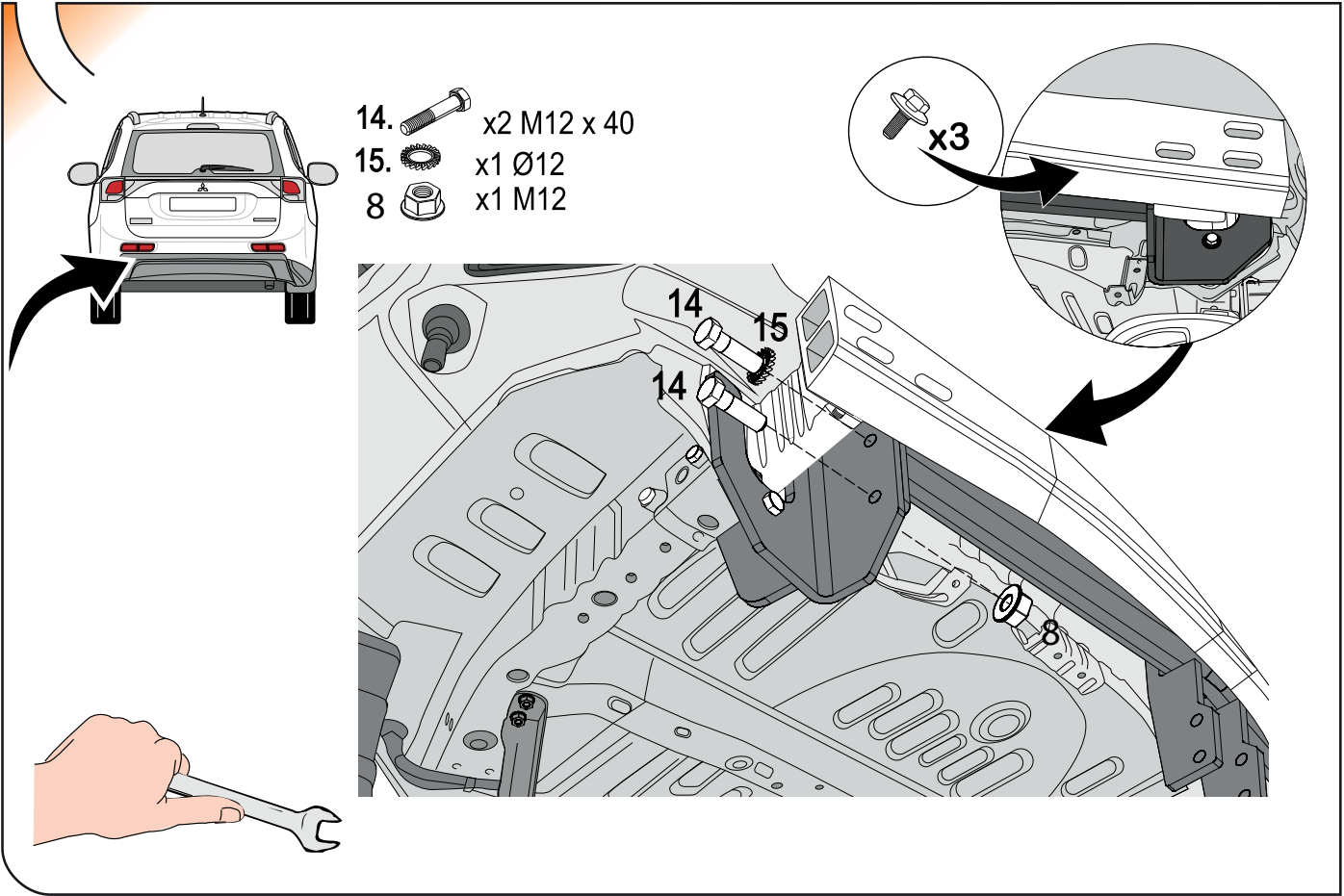

16

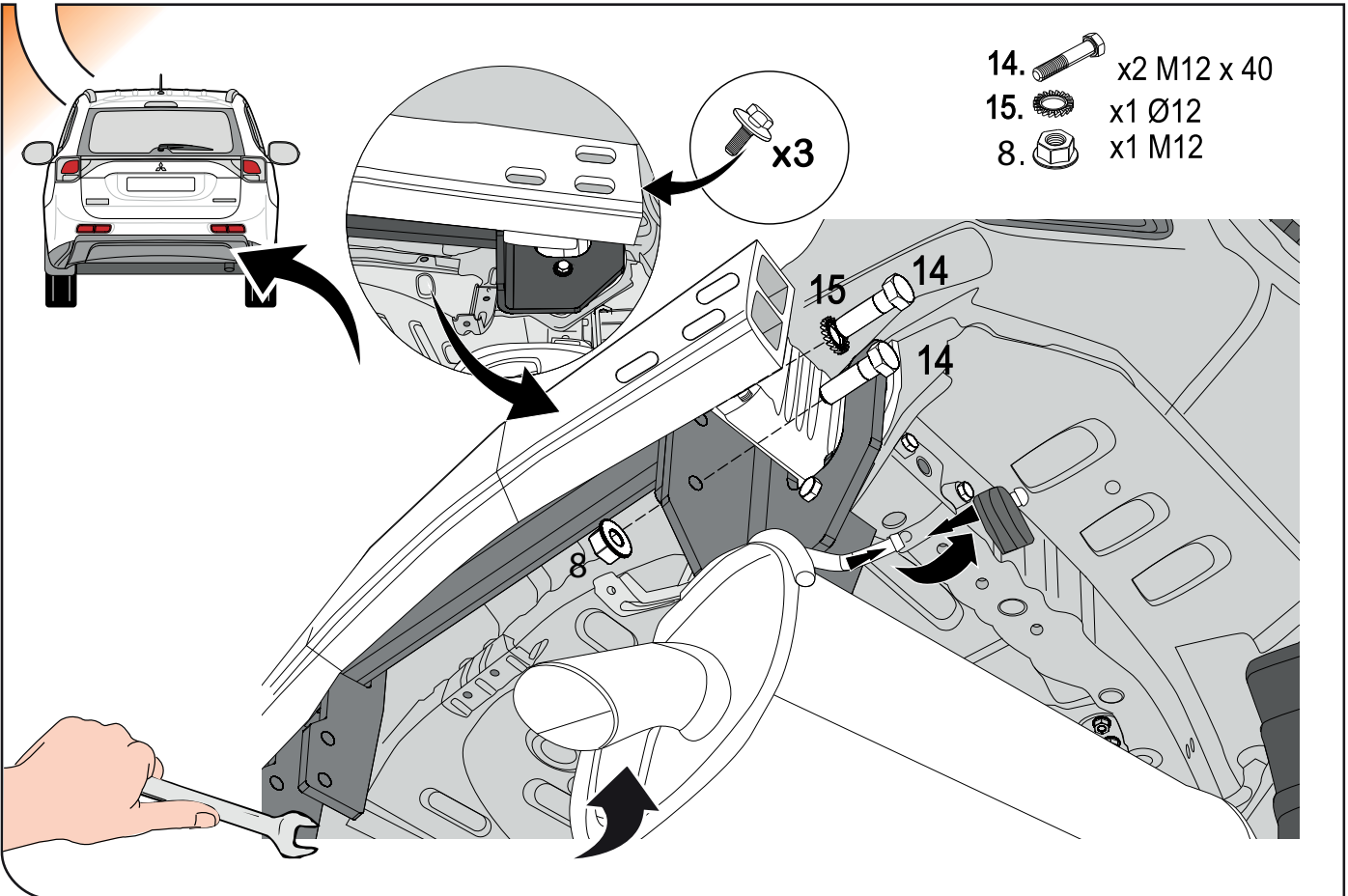

17

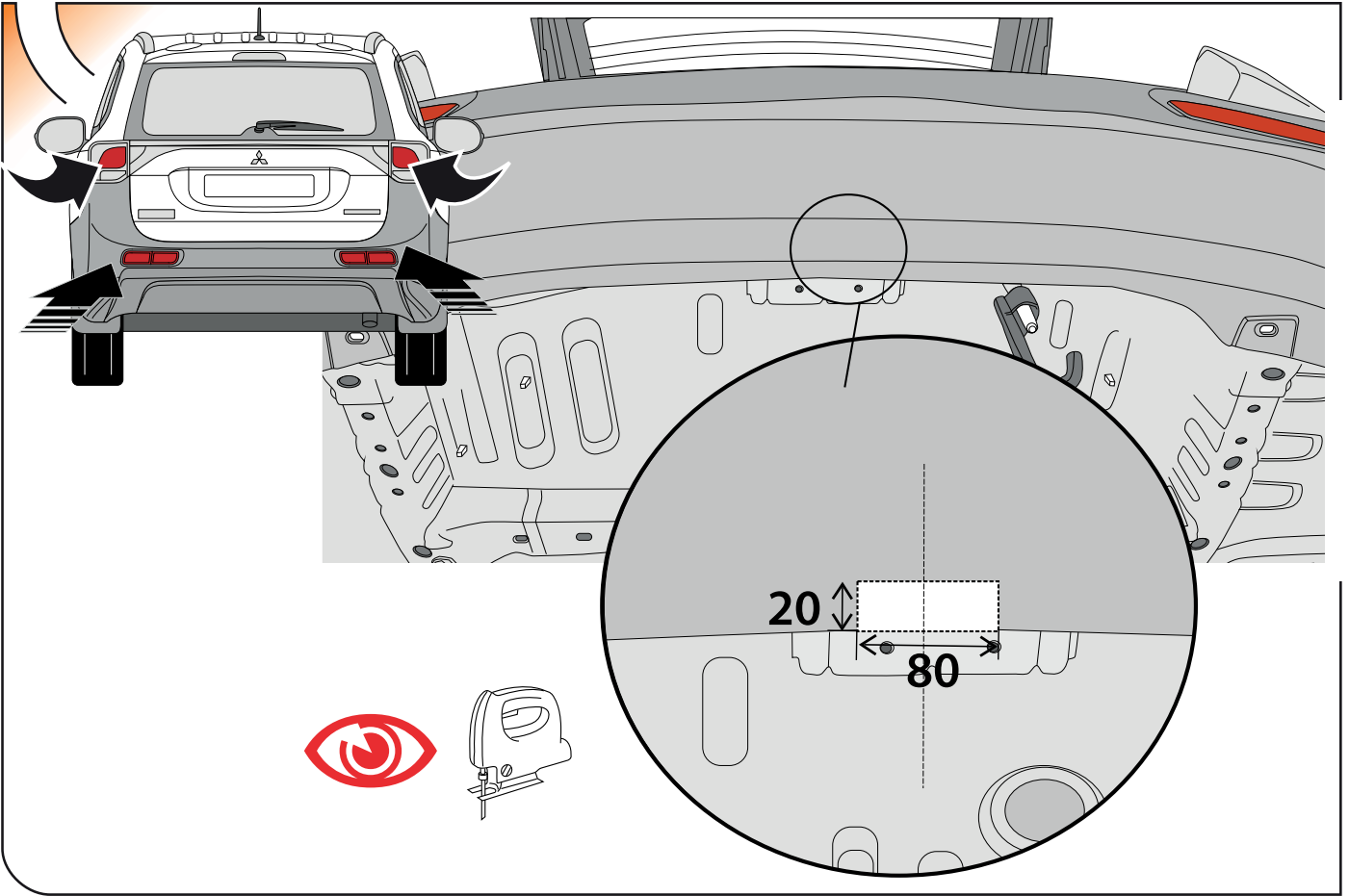

18

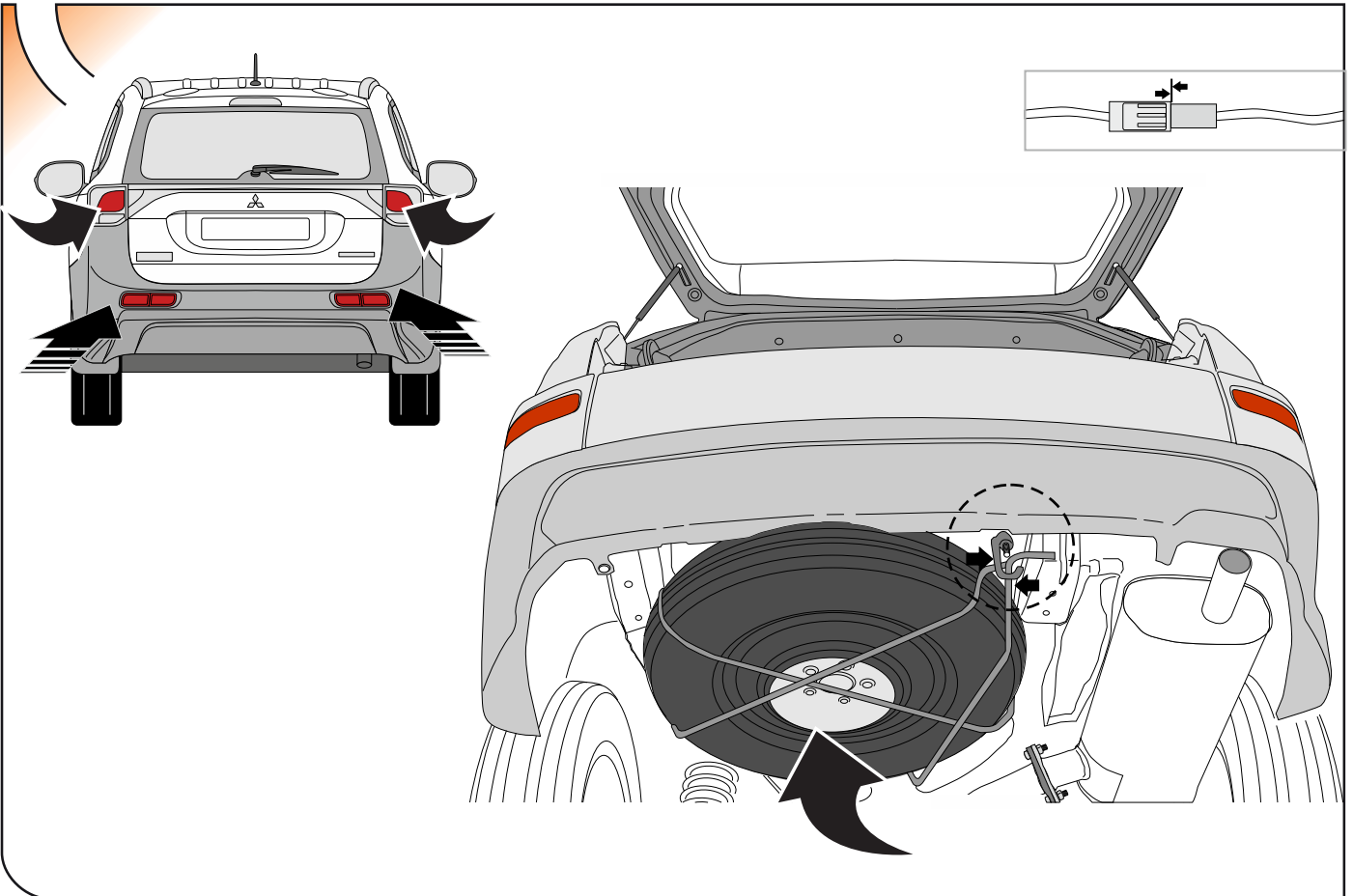

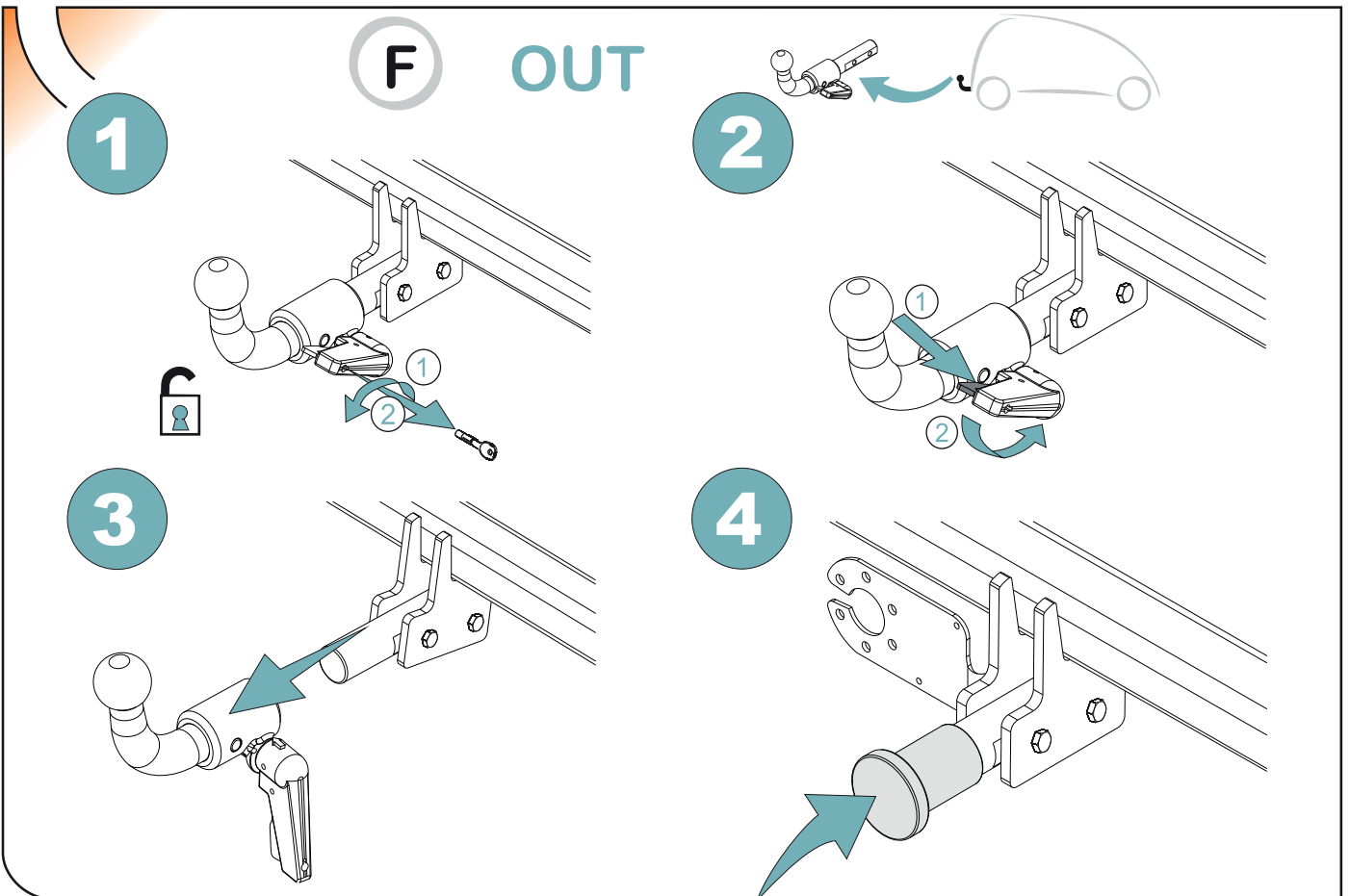
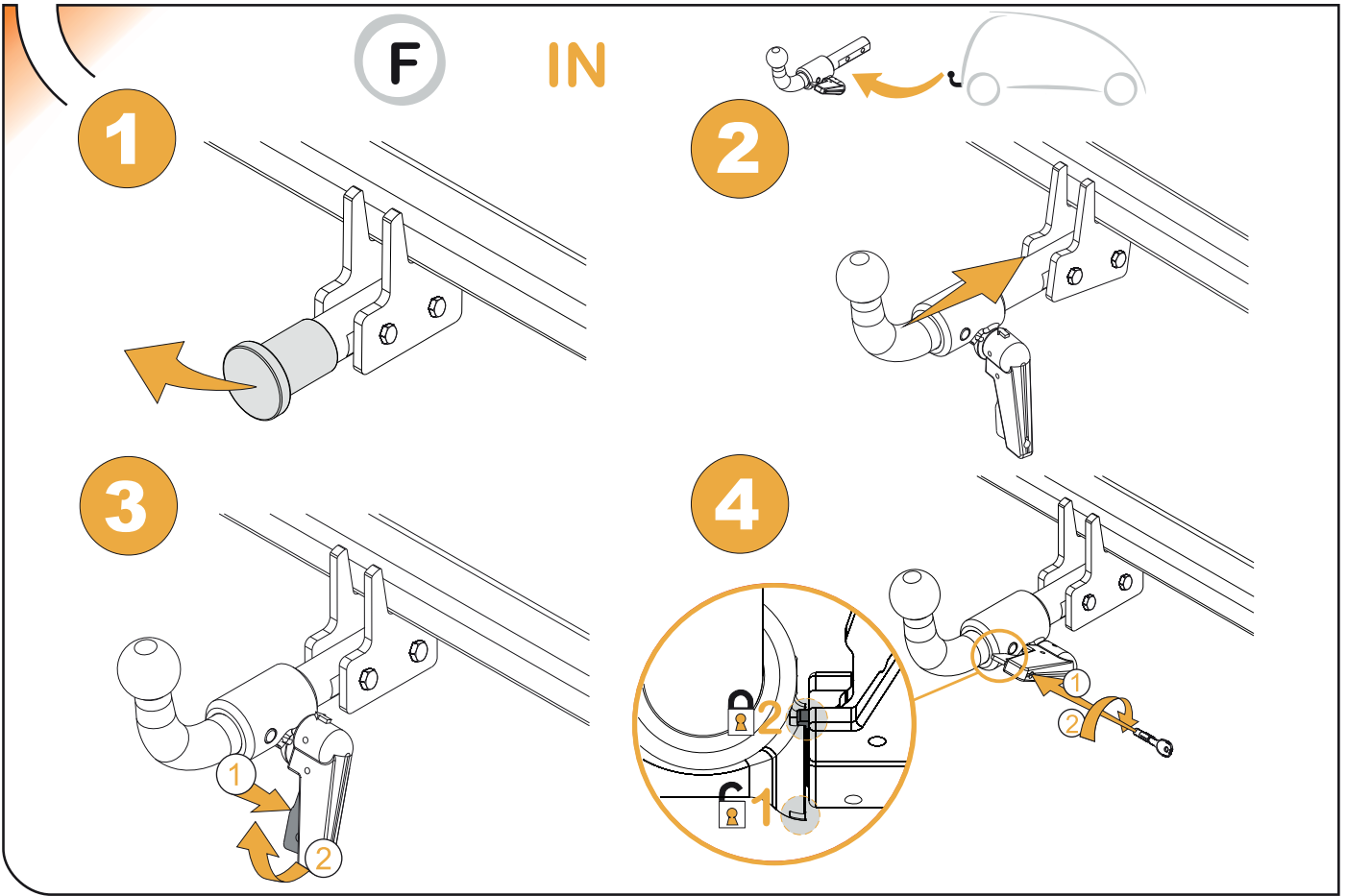

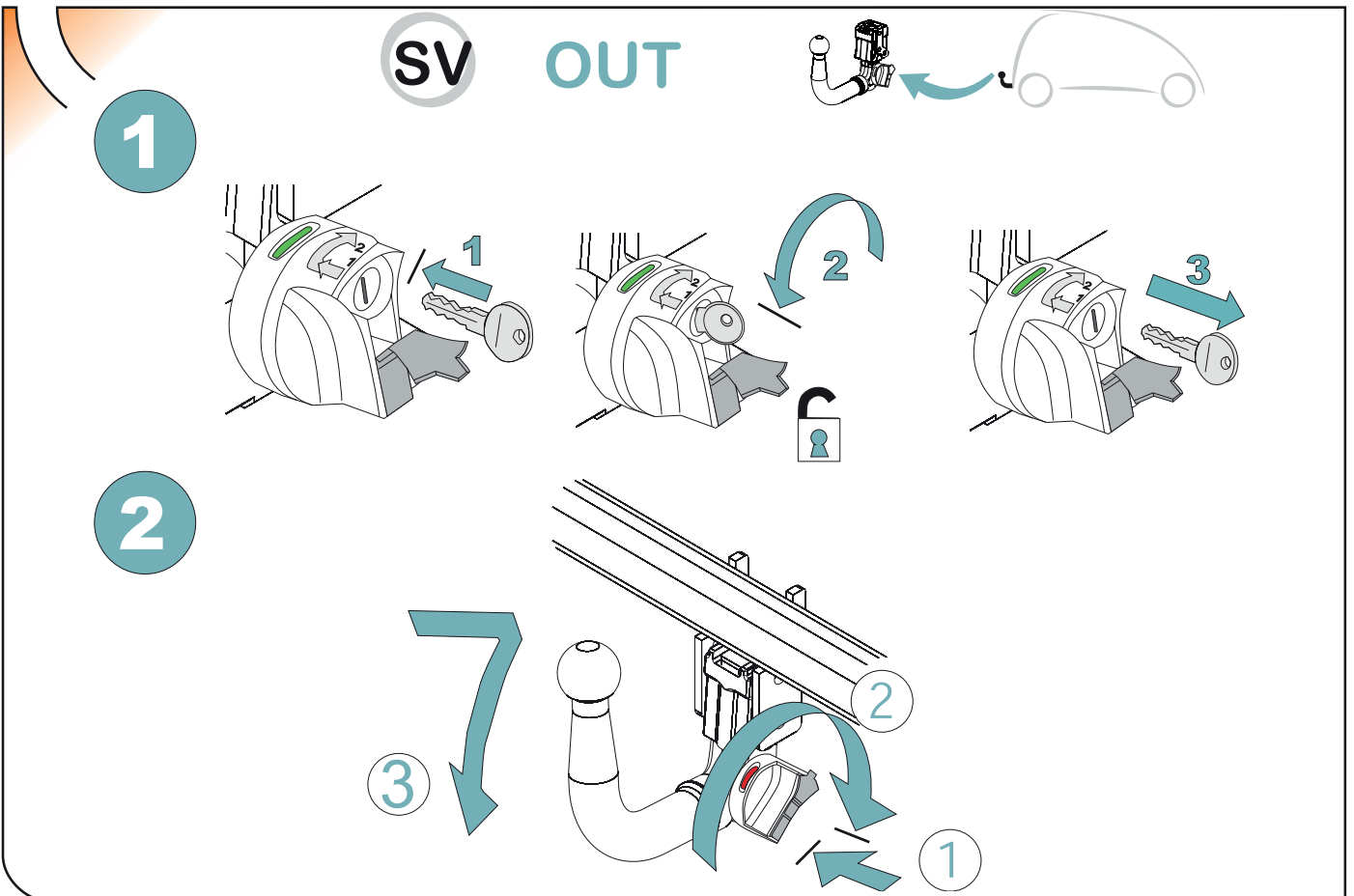
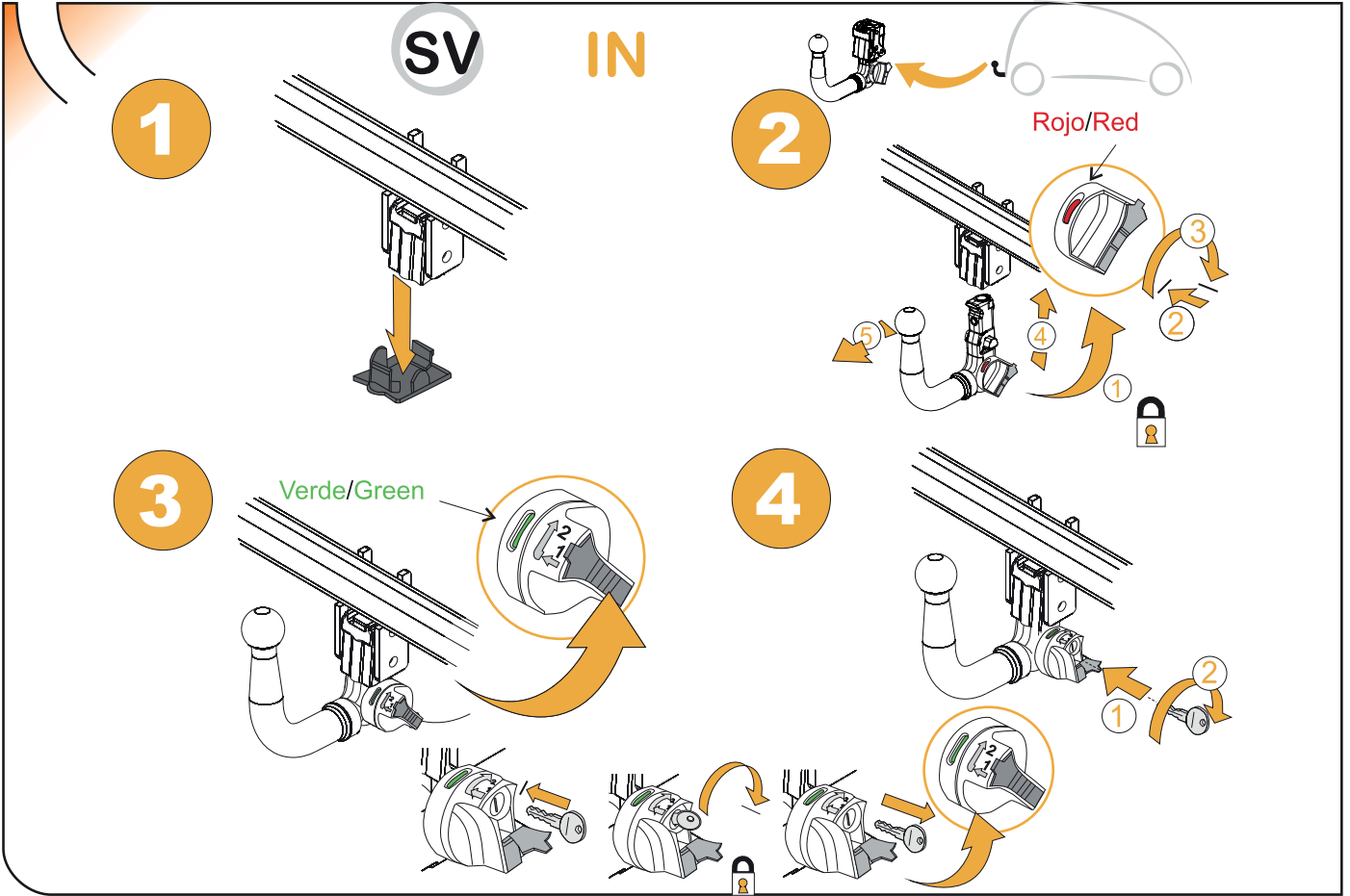

ANEXO III

CERTIFICADO DE TALLER

D. _____, expresamente autorizado por la _____
domiciliada en _____, teléfono _____, dedicada
a la actividad de _____ n° de Registro Industrial _____ y n° de registro
especial _____.

CERTIFICA

Que la mencionada empresa ha realizado la/s Reforma/s y asume la responsabilidad de la ejecución,
sobre el vehículo marca....., tipo.....
variante..... denominación comercial
matrícula y n° de bastidor, de acuerdo con:

- La normativa vigente en materia de reformas de vehículos.
- Las normas del fabricante del vehículo aplicables a la/s reforma/s llevadas a cabo en dicho vehículo.
- El proyecto descriptivo de la/s reforma/s, adjunto al expediente.

OBSERVACIONES: (2)

Tipificada/s con el código de reforma/s.....
Reforma consiste en:

COLOCACION DE ENGANCHE _____

n° de identificación / marca de homologación

Type :

Fecha:

Firma y sello:

Fdo:

(1) En el caso de que la reforma sea efectuada por el fabricante se indicará N/A.

(2) Se debe especificar en este apartado OBSERVACIONES, la identificación de los equipos o sistemas modificados, garantizando que se cumple lo previsto en el artículo 6 del reglamento general de vehículos y, en su caso, en el artículo 5 del R. D. 1457/1986 de 10 de enero, por el que se regula la actividad industrial en talleres de vehículos automóviles, de equipos y sus componentes, modificado por 455/2010 de 16 de abril, por el que se modifica el R. D. 1457/1986 de 10 de enero por el que se regulan la actividad industrial y la prestación.

ES

1



2

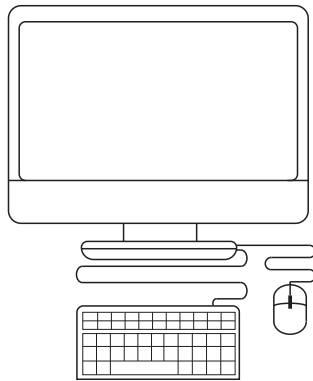

3



IT

1

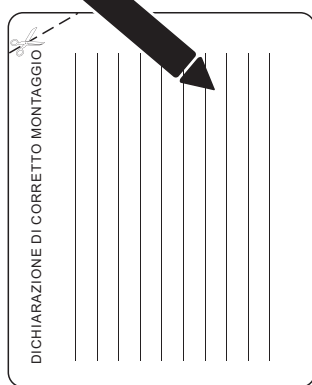

2

