

Ford Kuga (2008-2012)
Ford Kuga (2013-2016)
Ford Kuga (2017-)

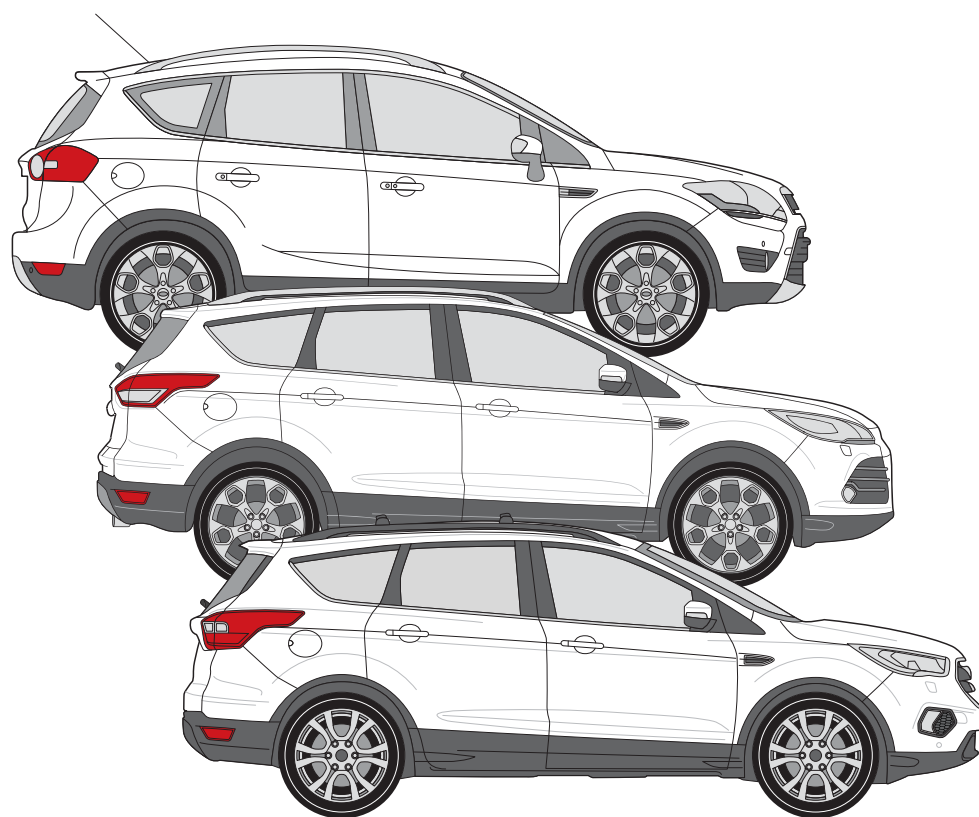

94/20/EC

Ford Kuga (2008-2012)
 Ford Kuga (20013-2016)
 Ford Kuga (2017-)

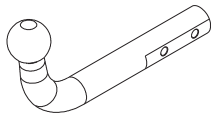

| | | |
|-----|----------------|------------|
| e13 | APPROVALNUMBER | D-VALUE |
| | 00-2819 | D 10,67 kN |
| | TYPE | CLASS |
| | FOR036 | A50-X |
| | MAX.VERT.LOAD | |
| | S 90 kg | |

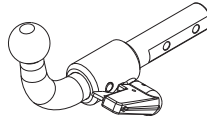

| | | |
|-----|----------------|------------|
| e13 | APPROVALNUMBER | D-VALUE |
| | 00-2820 | D 10,67 kN |
| | TYPE | CLASS |
| | FOR037-S | A50-X |
| | MAX.VERT.LOAD | |
| | S 90 kg | |

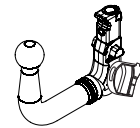

| | | |
|-----|----------------|------------|
| e13 | APPROVALNUMBER | D-VALUE |
| | 00-2820 | D 10,67 kN |
| | TYPE | CLASS |
| | FOR037-V | A50-X |
| | MAX.VERT.LOAD | |
| | S 90 kg | |

D = 10,67 kN



T = 2200 Kg



S = 90 kg

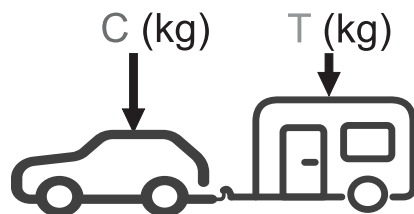
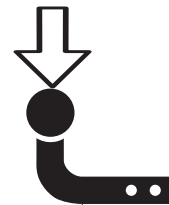

$g = 9,81 \text{ m/s}^2$

$$D \geq \frac{T \cdot C}{T + C} \cdot \frac{g}{1000} \text{ (kN)}$$

$$T \leq \frac{C \cdot D \cdot 1000}{(C \cdot g) - (1000 \cdot D)} \text{ (kg)}$$

| | | | | | |
|--|-----|-----|-----|-----|-----|
| | M8 | M10 | M12 | M14 | M16 |
| | N/m | 20 | 40 | 60 | 105 |

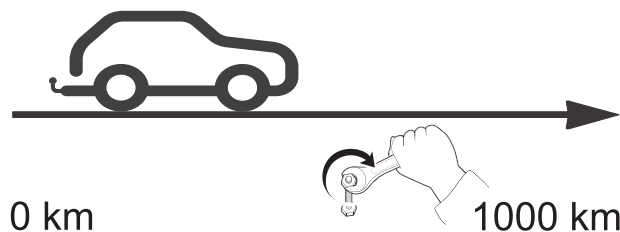

12. x4 M10 x 35 → Ford Kuga (2008-2012)







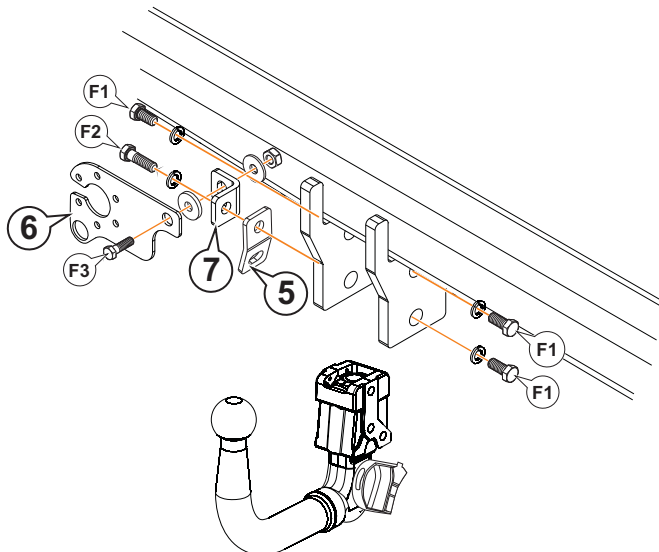
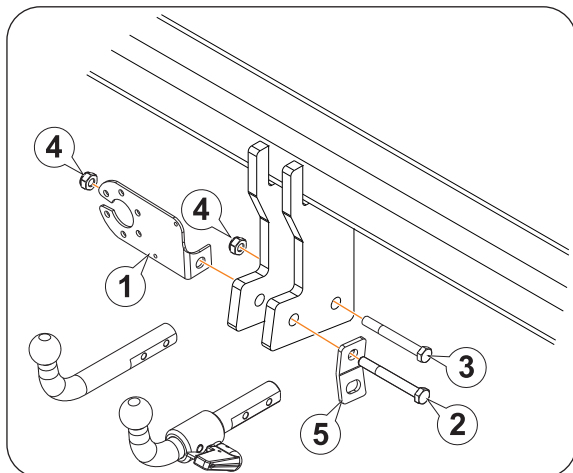
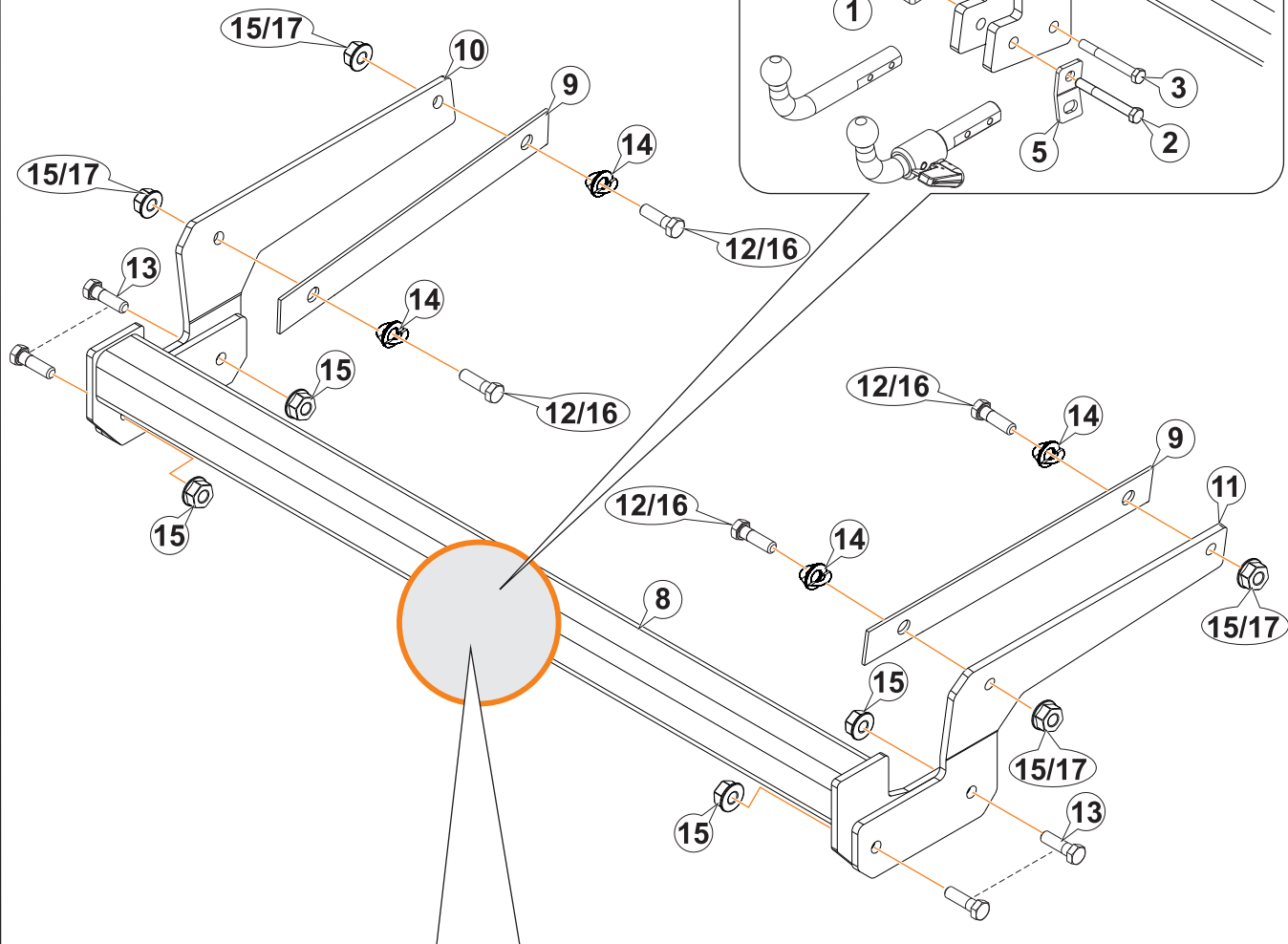



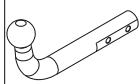
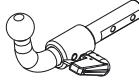
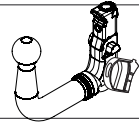

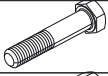
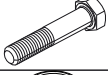

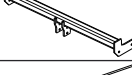

15. x4 M10 → Ford Kuga (2008-2012)

16. x4 M12 x 35 → Ford Kuga (2013-2016), (2017-)

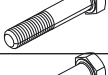
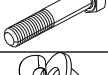
17. x4 M12 → Ford Kuga (2013-2016), (2017-)

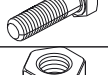

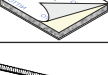
| | | # |
|-----------|-------------------------|---|
| F1 | M12 x 25 DIN 933 | 3 |
| | Ø12 Grower DIN 128 | 3 |
| F2 | M12 x 35 DIN 933 | 3 |
| | Ø12 Grower DIN 128 | 1 |
| F3 | M10 x 30 DIN 933 | 1 |
| | Ø10 Poliuretano / Nylon | 1 |
| | Ø10 DIN 9021 | 1 |
| | M10 DIN 980 | 1 |

| | | |  |  |  |
|----|---|---|--|---|---|
| 1 |  | AEV0005 | 1 | | |
| 2 |  | M10x70 DIN 931(8.8) | 1 | | |
| 3 |  | M10x65 DIN 931(8.8) | 1 | | |
| 4 |  | M10 DIN 980 | 2 | | |
| 5 |  | AEV0006 | 1 | | 1 |
| 6 |  | AEV0009 | | | 1 |
| 7 |  | AEV0008 | | | 1 |
| 8 |  | C2020A | 1 | | 1 |
| 9 |  | C2020AA21 | 2 | | 2 |
| 10 |  | C2020AV21 | 1 | | 1 |
| 11 |  | C2020AV21.1. | 1 | | 1 |
| 12 |  | M10x35 DIN 933 (KUGA 2008-2012) | 4 | | 4 |
| 13 |  | M12x40 DIN 933 | 4 | | 4 |
| 14 |  | A_0 | 4 | | 4 |
| 15 |  | M10 DIN 6923 (KUGA 2008-2012) | 4 | | 4 |
| 16 |  | M12x35 DIN 933 (KUGA 2013-2016), (2017-) | 4 | | 4 |
| 17 |  | M12 DIN 6923 (KUGA 2013-2016), (2017-) | 8 | | 8 |
| 18 |  | ALV0C03 (Kuga 2017-) | 2 | | 2 |
| 19 |  | AEB_0 (KUGA 2017-) | 2 | | 2 |

1

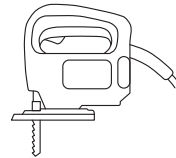
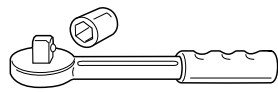
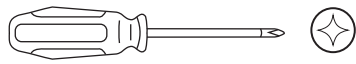
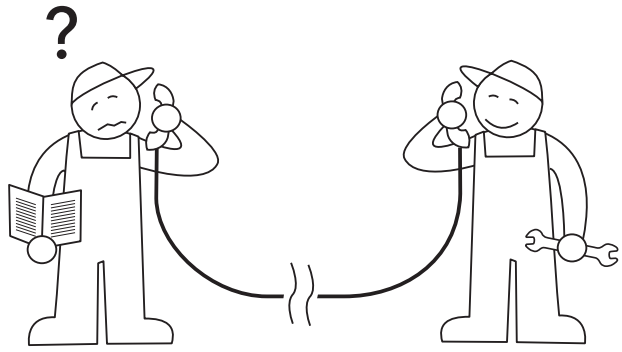
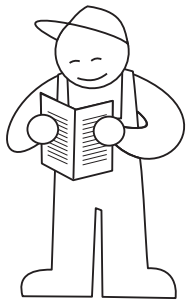

2

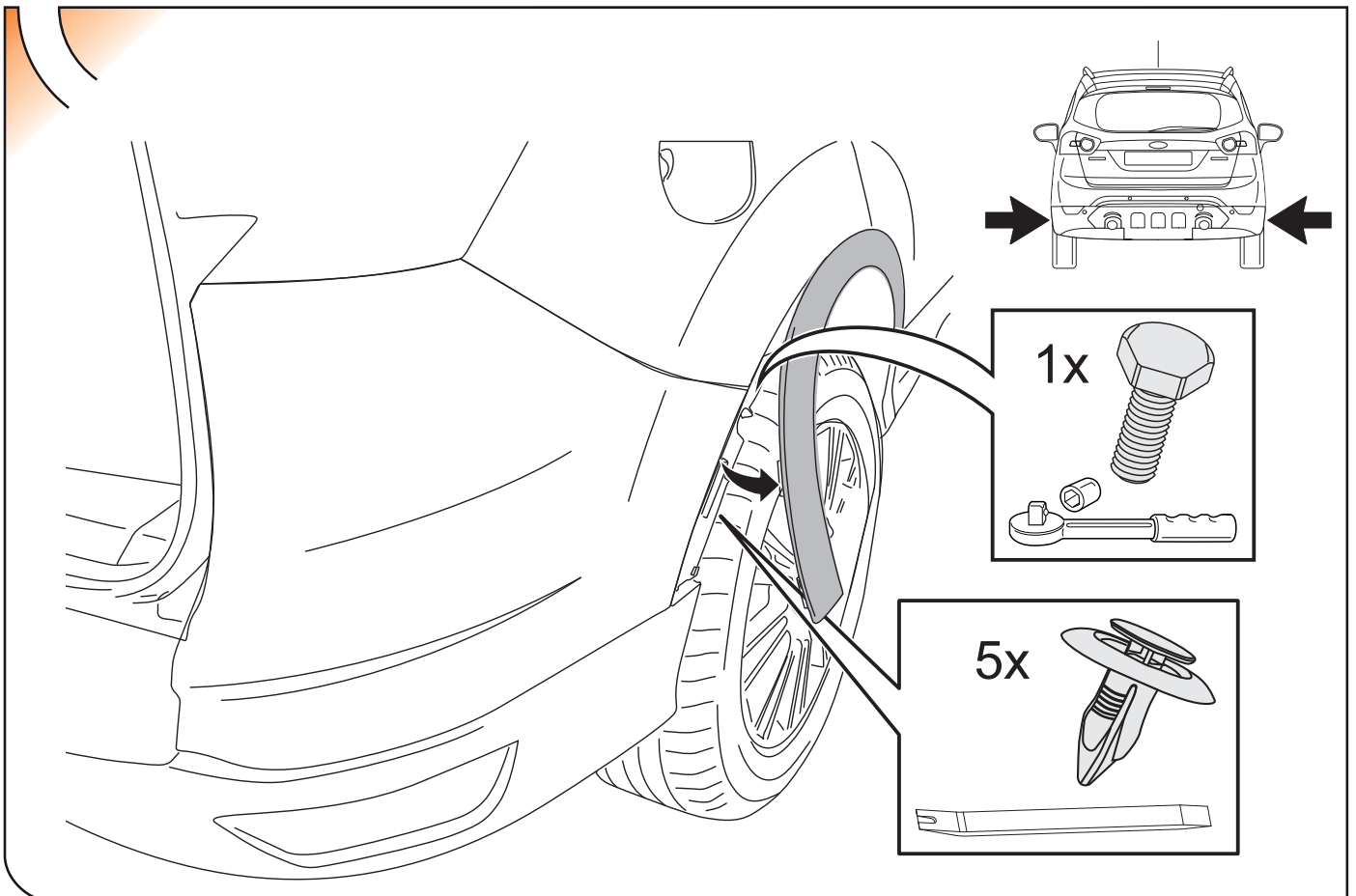

3

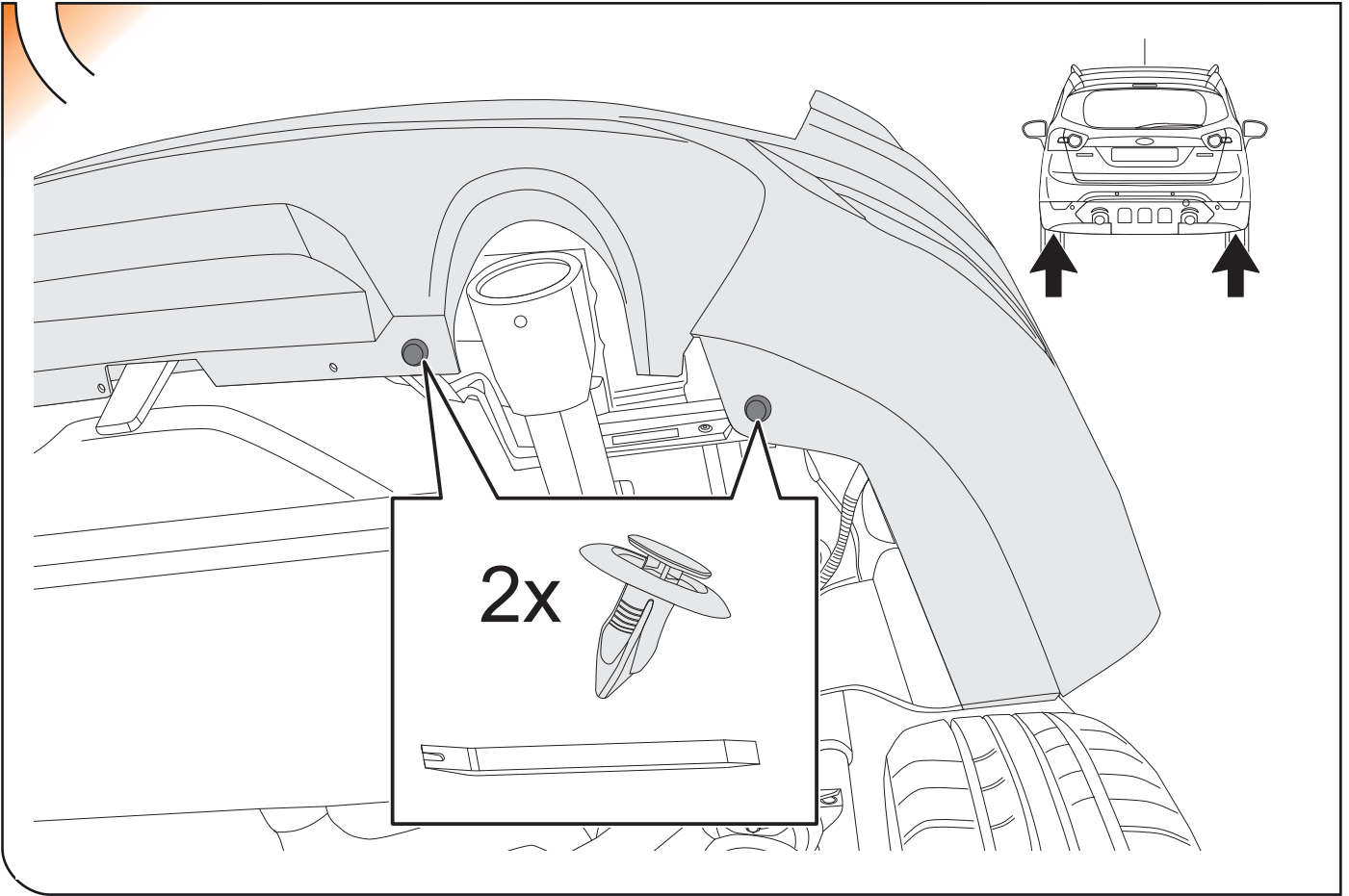

4

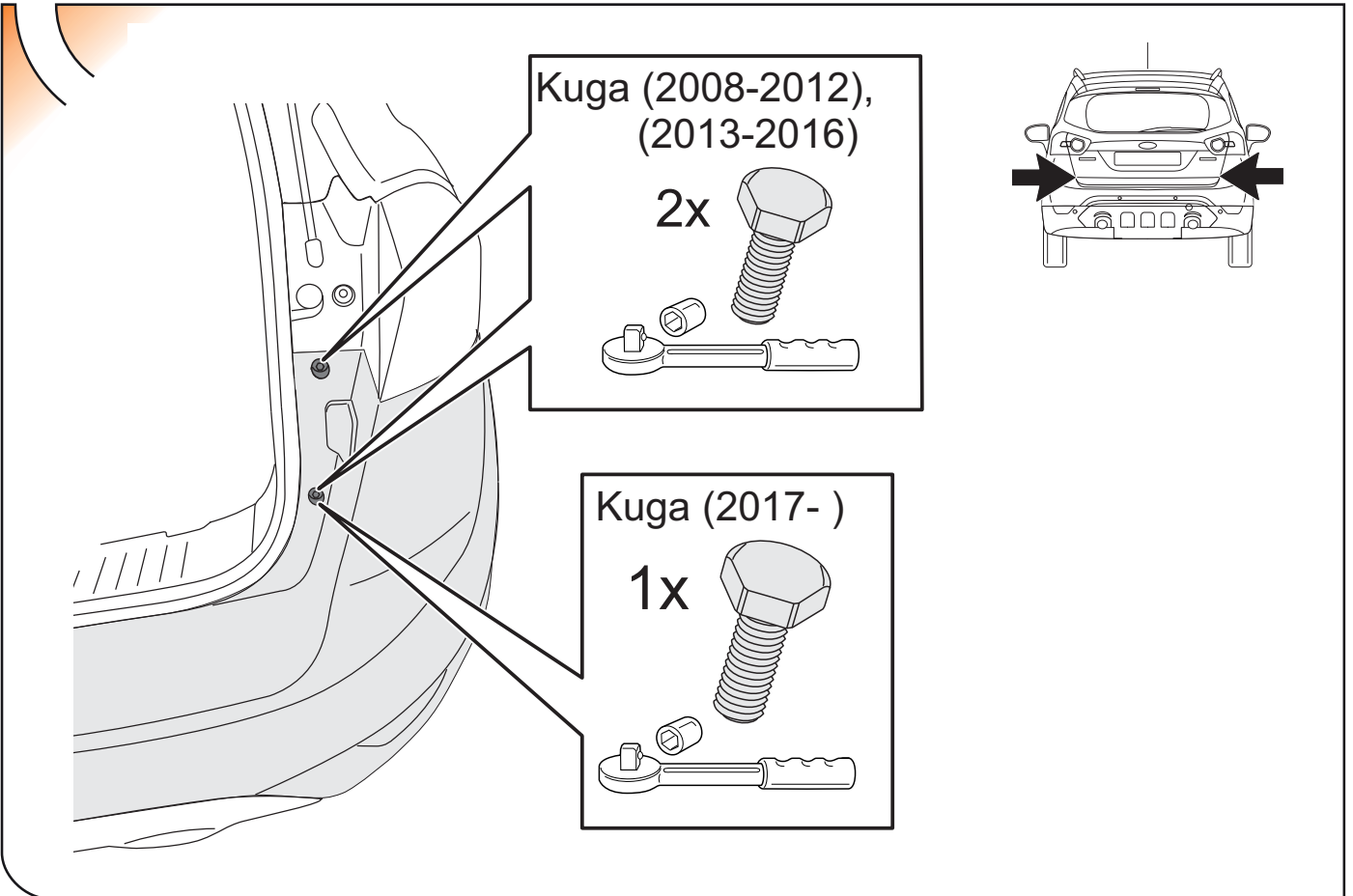

5

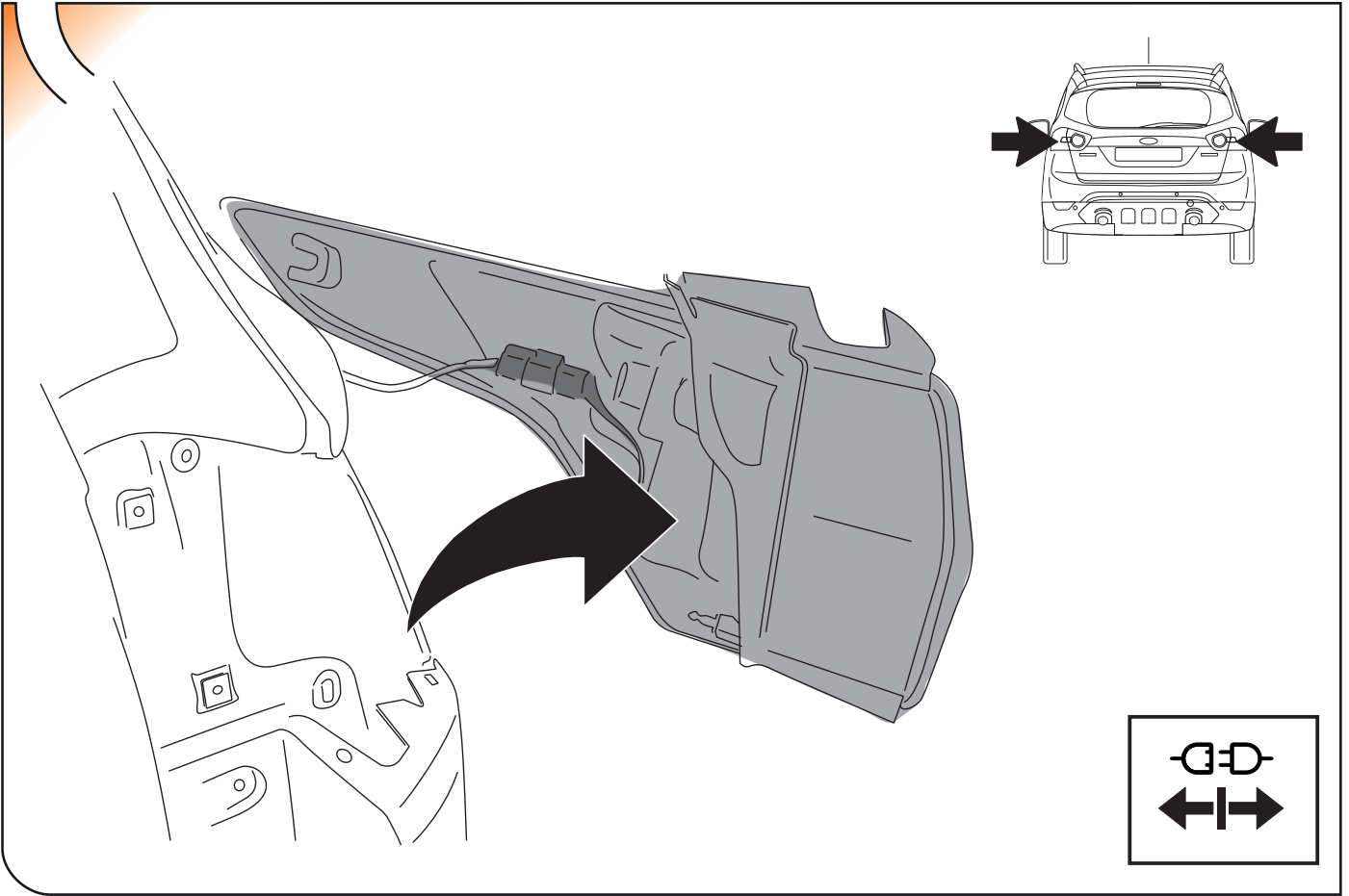

6

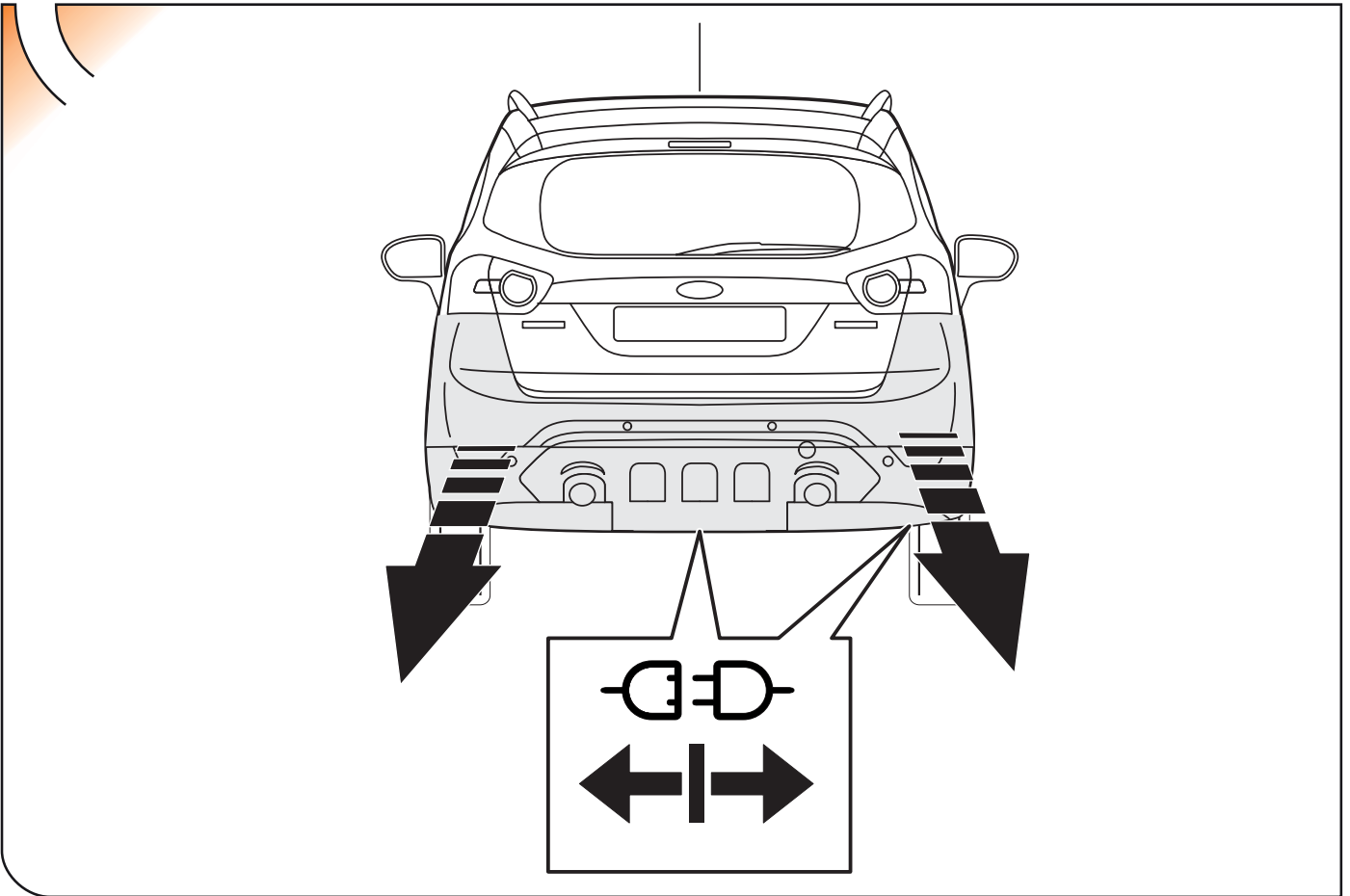

7

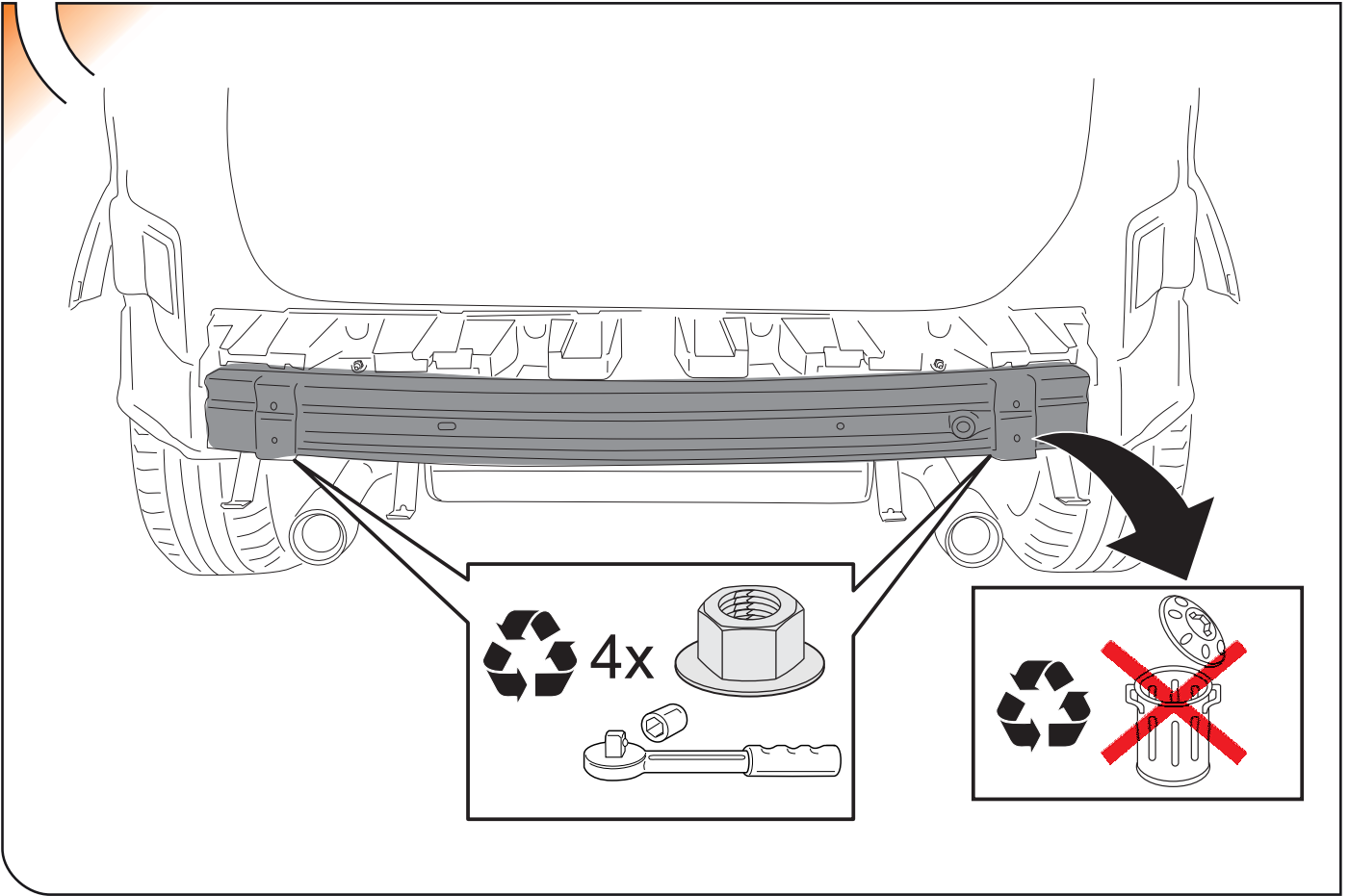

8

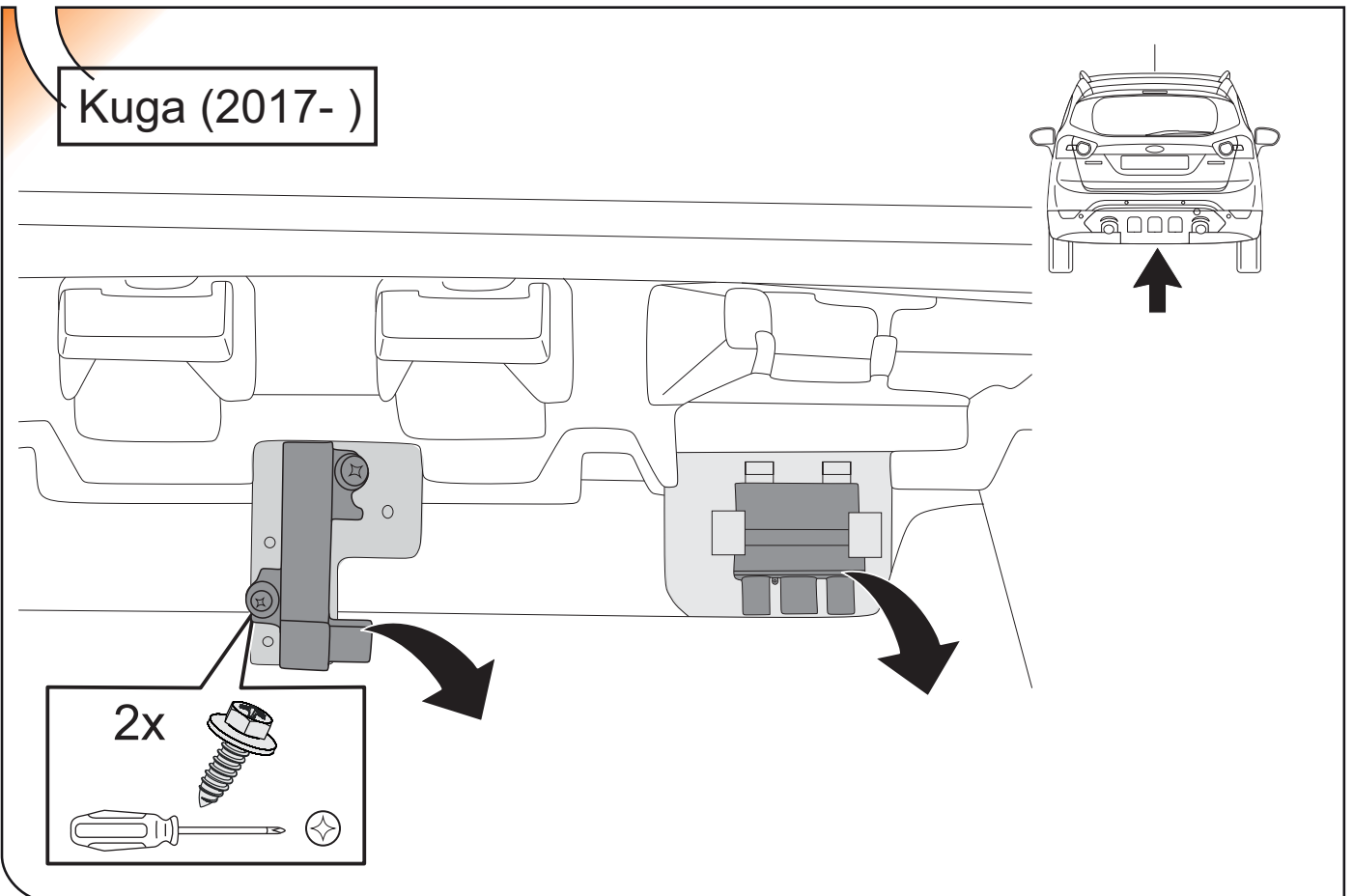

9

Kuga (2017-)

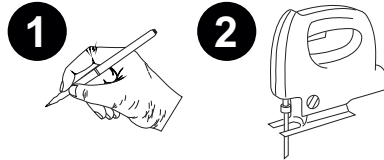
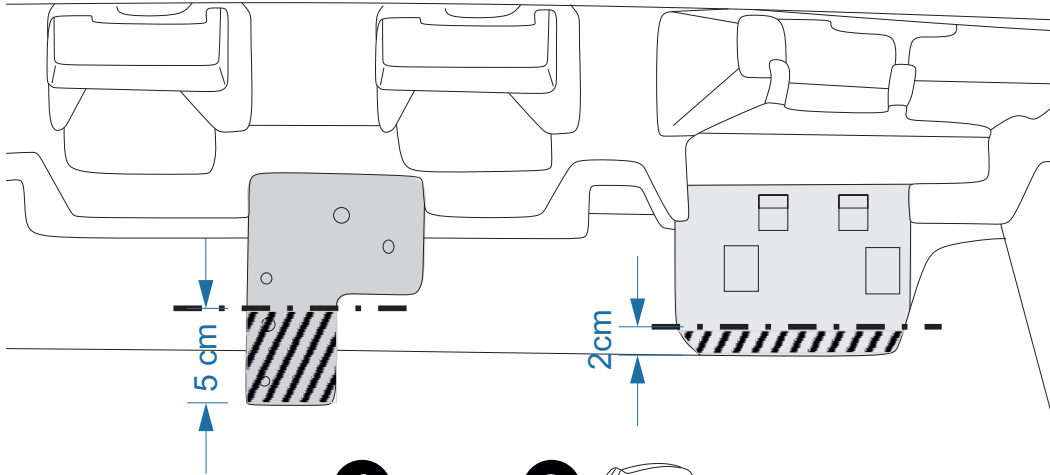
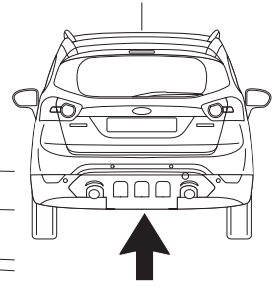

10

Kuga (2017-)

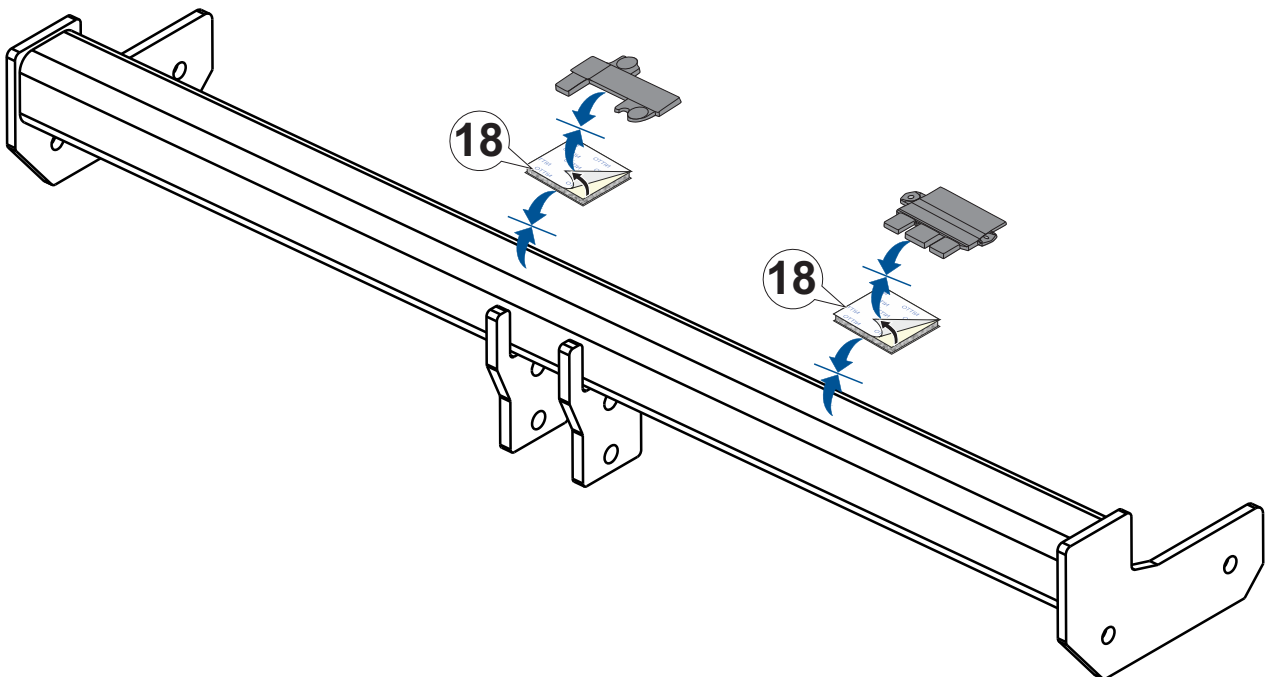

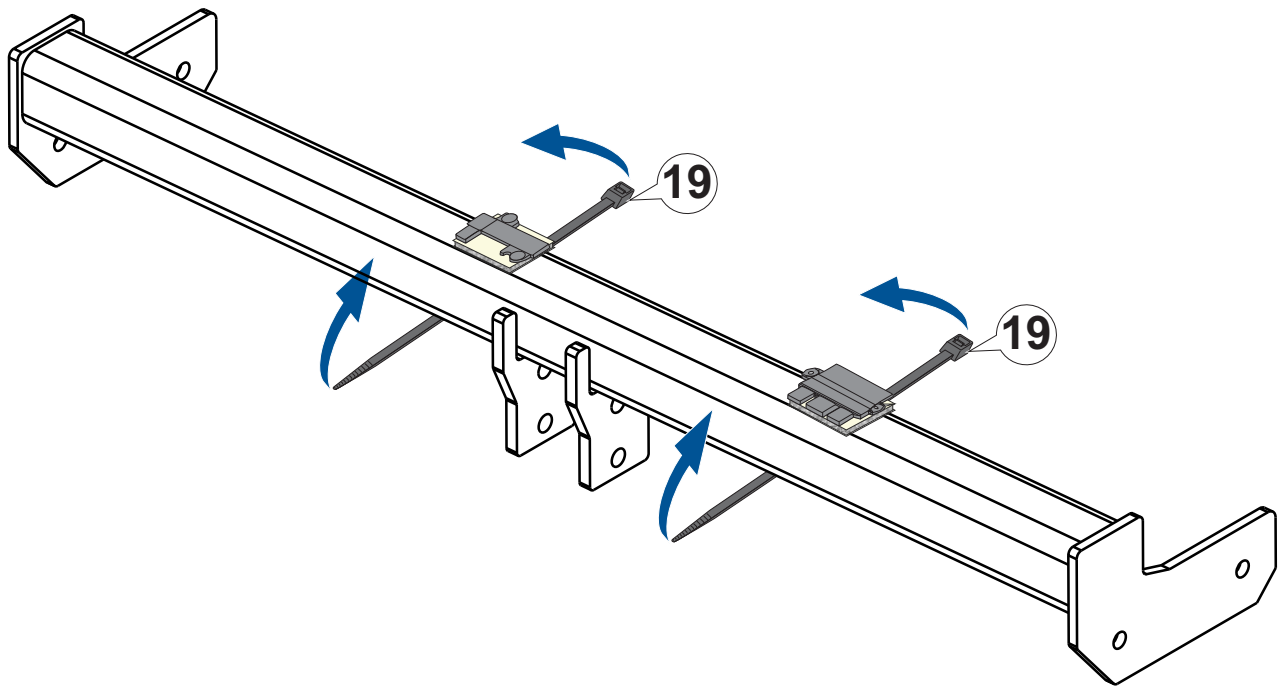

11

Kuga (2017-)



12

- 12.  → Ford Kuga (2008-2012)
- 16.  → Ford Kuga (2013-2016), (2017-)

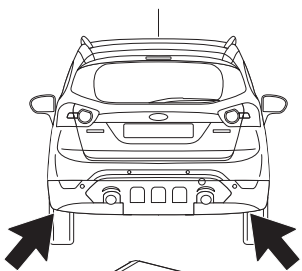

1

12/16

14

9

2

11

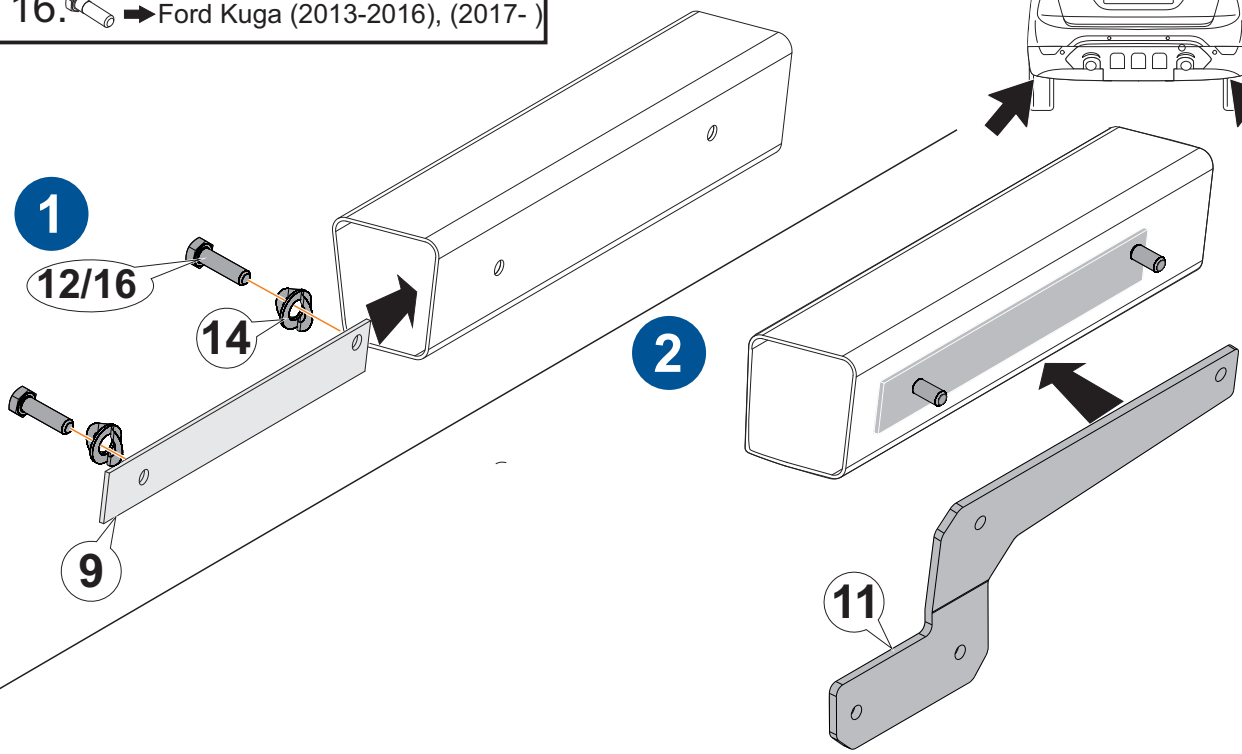

13

15.  → Ford Kuga (2008-2012)

17.  → Ford Kuga (2013-2016), (2017-)

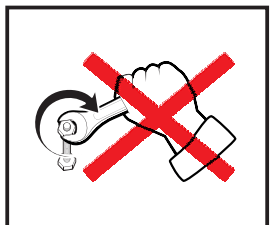
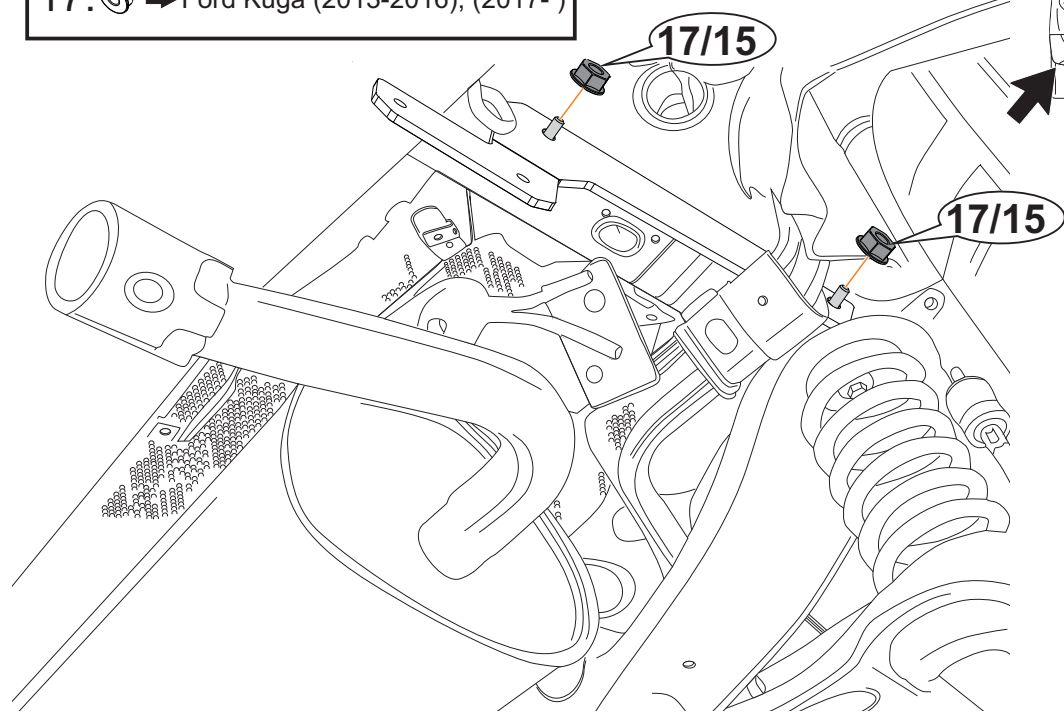
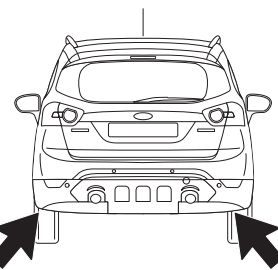

14

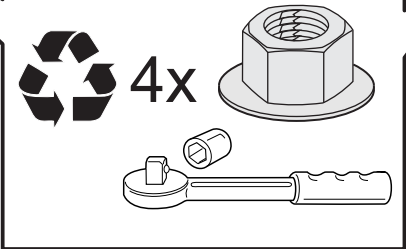
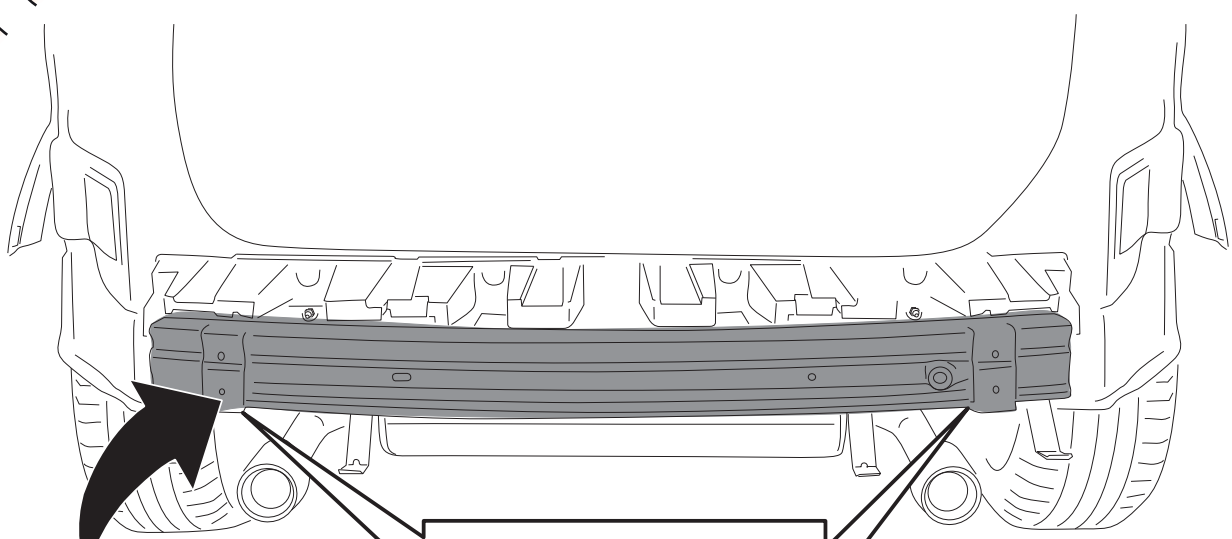

15

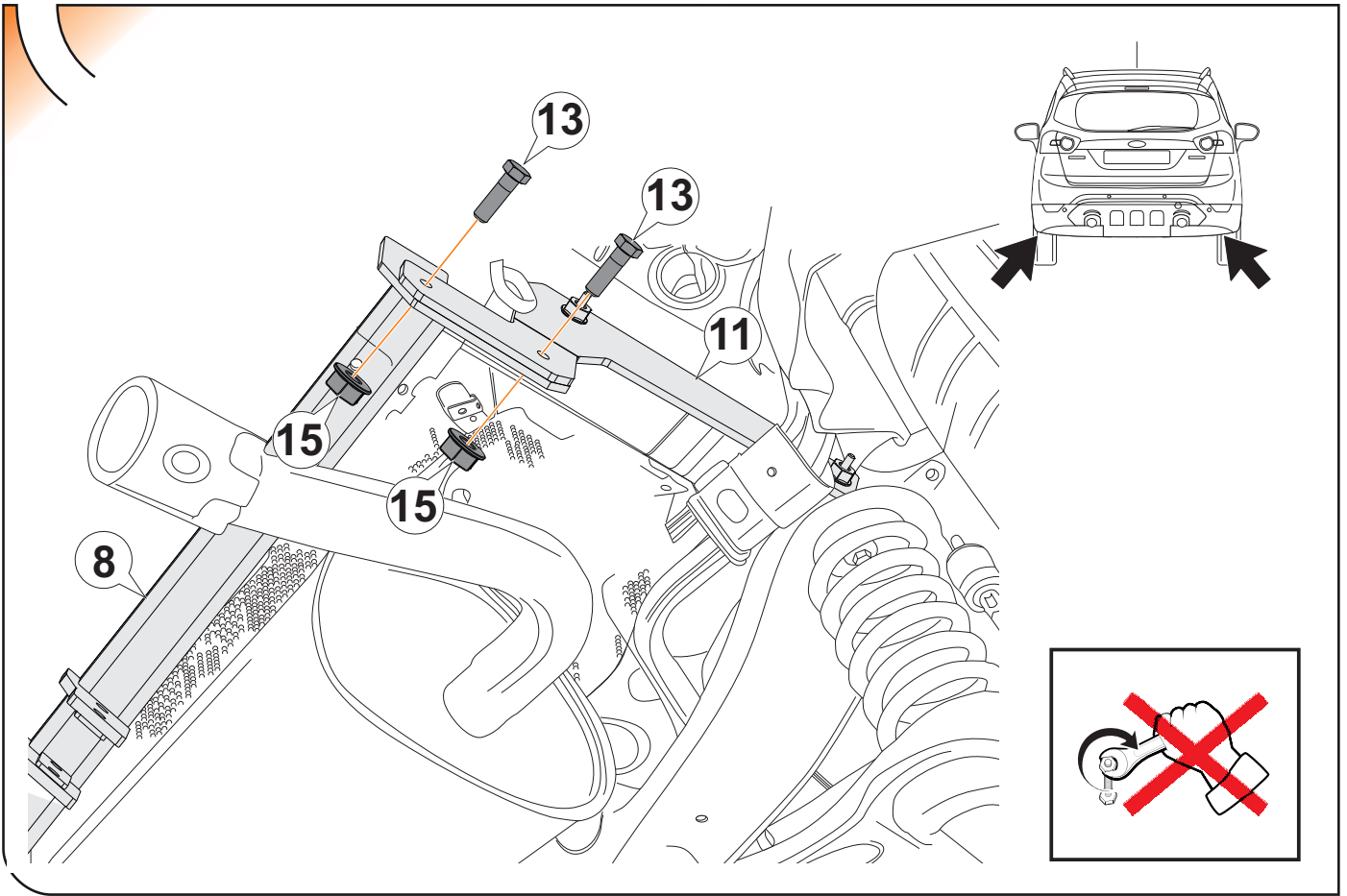

16

|  | M8 | M10 | M12 | M14 | M16 |
|---|----|-----|-----|-----|-----|
| N/m | 20 | 40 | 60 | 105 | 160 |

Diagram illustrating the correct torque application method. A hand is shown turning a nut with a torque wrench. Below the diagram is a table of torque specifications for different nut sizes. The table indicates that the torque wrench should be used for all sizes, and the correct torque value (Nm) should be applied. A warning icon shows a hand turning a nut with a red X over it, indicating that the nut should not be tightened by hand.

17

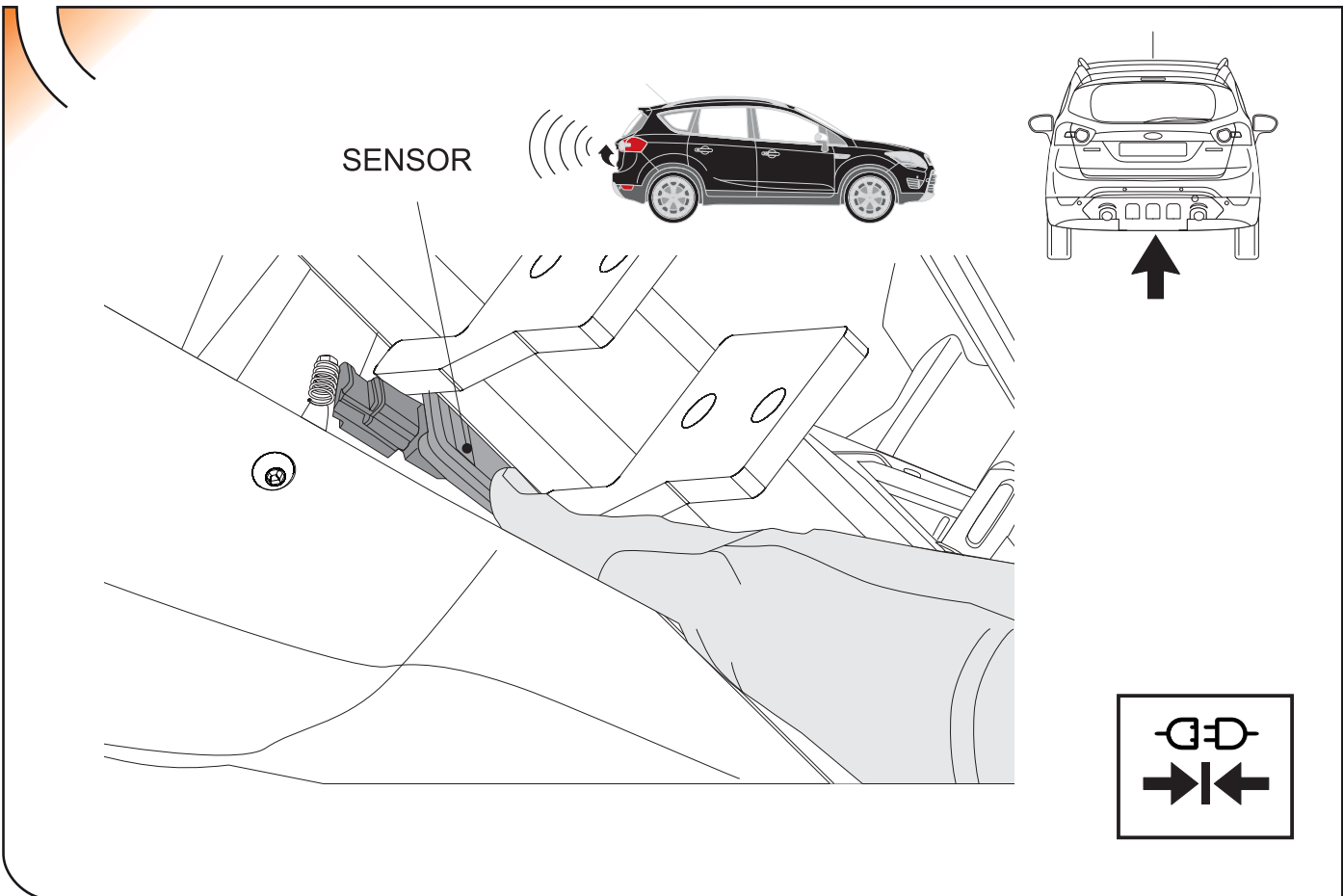

18

Kuga (2008-2012), (2013-2016)

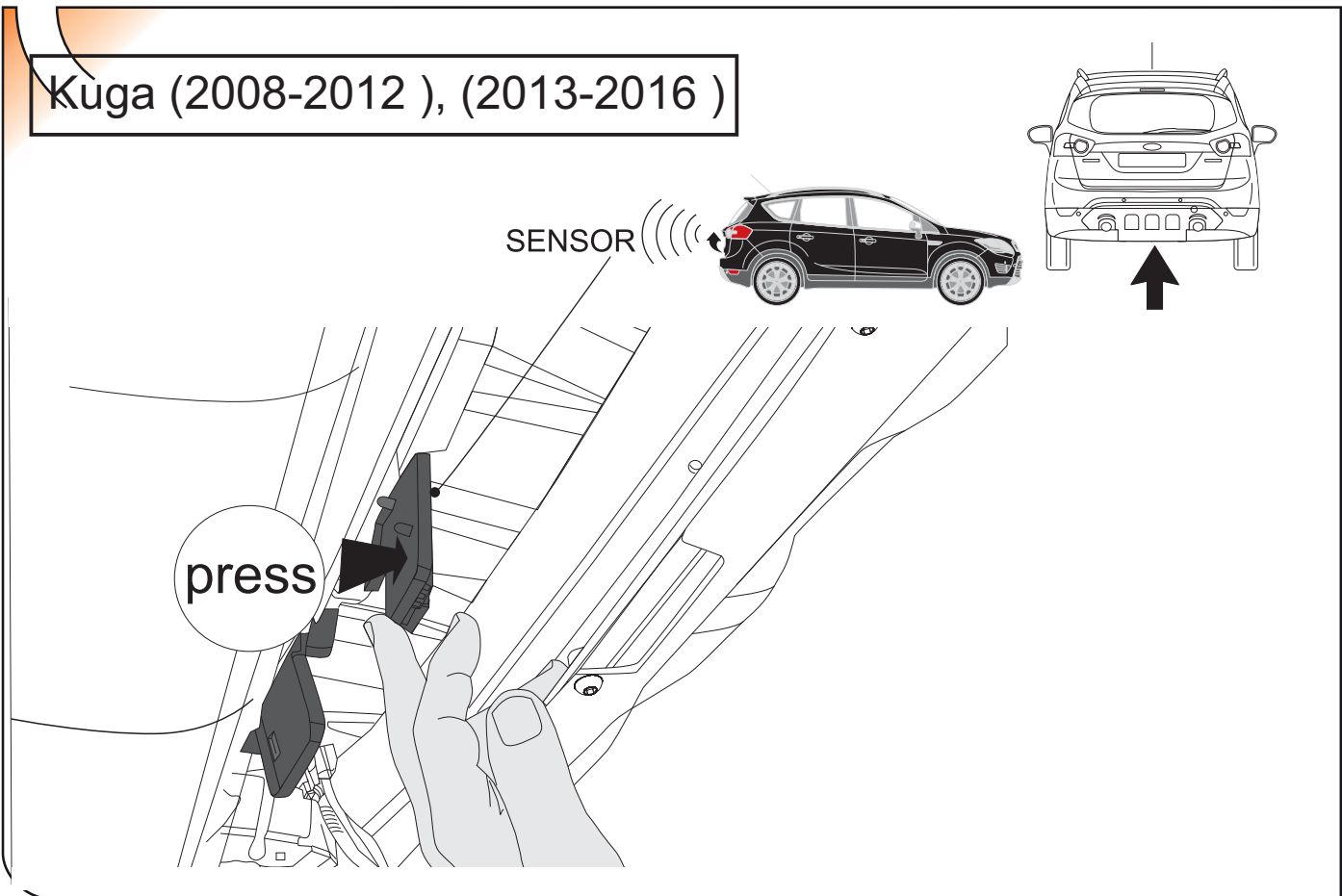

19

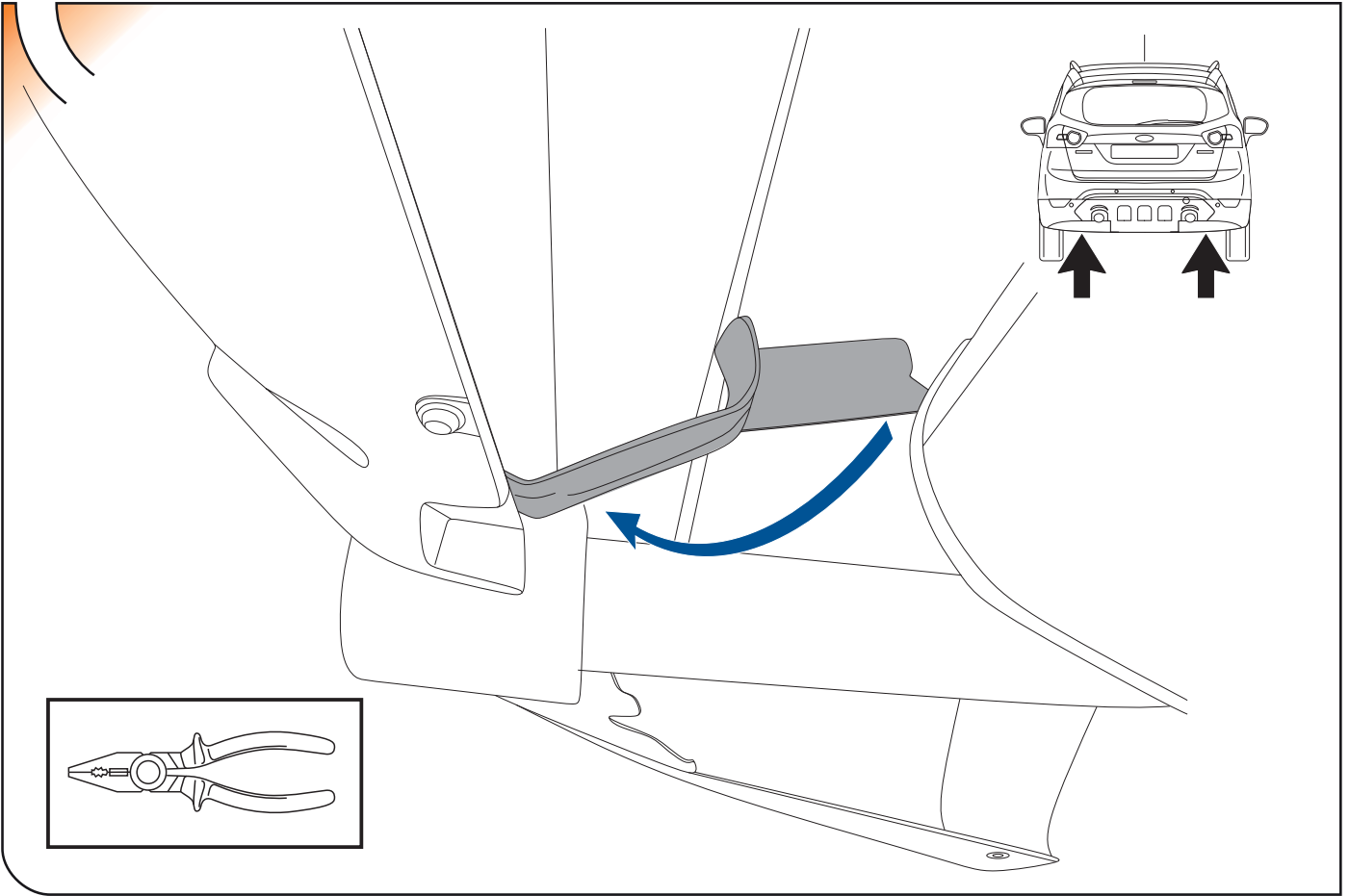

●

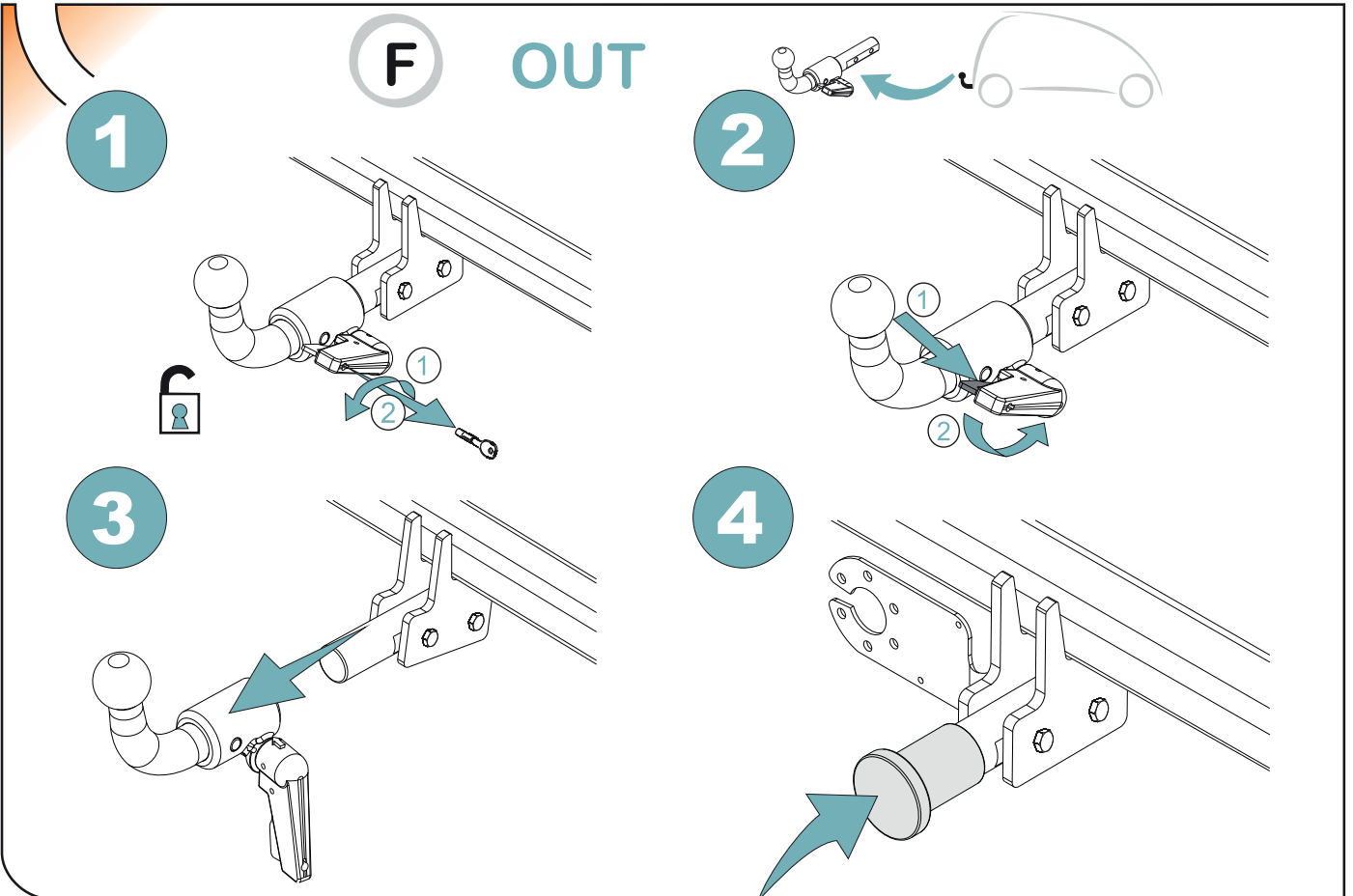

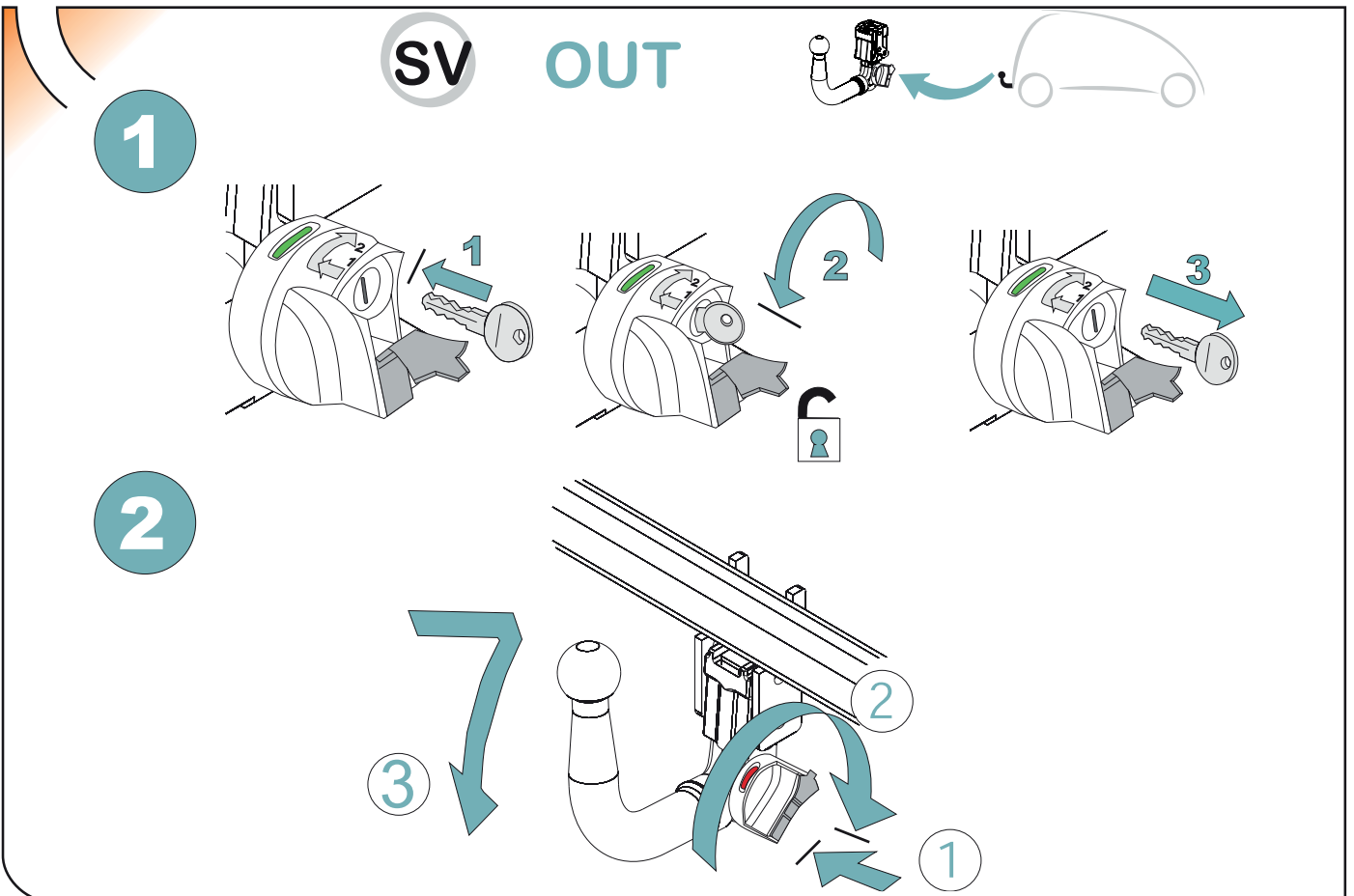
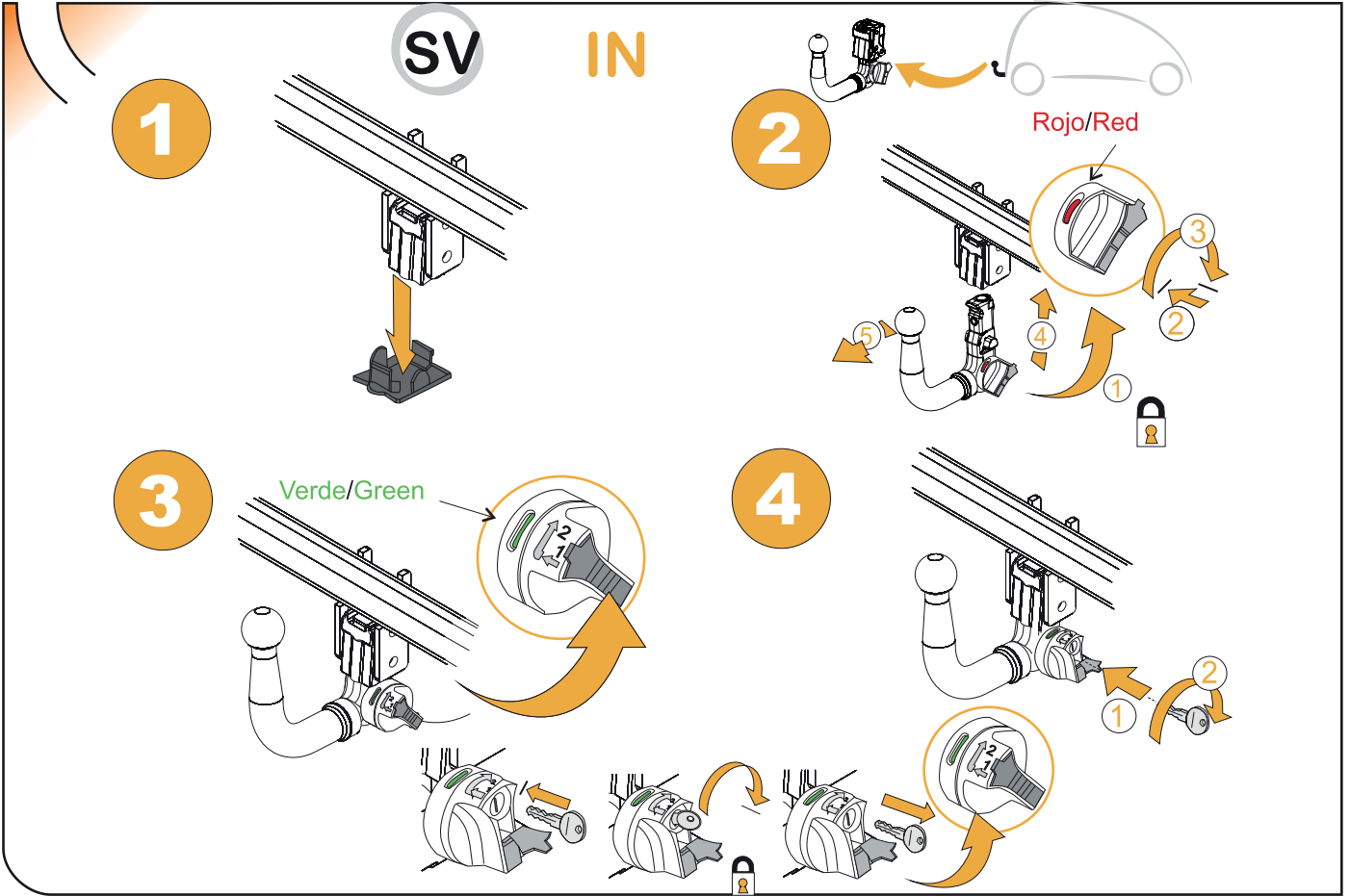

ANEXO III

CERTIFICADO DE TALLER

D. _____, expresamente autorizado por la _____
domiciliada en _____, teléfono _____, dedicada
a la actividad de _____ n° de Registro Industrial _____ y n° de registro
especial _____.

CERTIFICA

Que la mencionada empresa ha realizado la/s Reforma/s y asume la responsabilidad de la ejecución,
sobre el vehículo marca....., tipo.....
variante..... denominación comercial
matrícula y n° de bastidor, de acuerdo con:

- La normativa vigente en materia de reformas de vehículos.
- Las normas del fabricante del vehículo aplicables a la/s reforma/s llevadas a cabo en dicho vehículo.
- El proyecto descriptivo de la/s reforma/s, adjunto al expediente.

OBSERVACIONES: (2)

Tipificada/s con el código de reforma/s.....
Reforma consiste en:

COLOCACION DE ENGANCHE _____

n° de identificación / marca de homologación

Type :

Fecha:

Firma y sello:

Fdo:

(1) En el caso de que la reforma sea efectuada por el fabricante se indicará N/A.

(2) Se debe especificar en este apartado OBSERVACIONES, la identificación de los equipos o sistemas modificados, garantizando que se cumple lo previsto en el artículo 6 del reglamento general de vehículos y, en su caso, en el artículo 5 del R. D. 1457/1986 de 10 de enero, por el que se regula la actividad industrial en talleres de vehículos automóviles, de equipos y sus componentes, modificado por 455/2010 de 16 de abril, por el que se modifica el R. D. 1457/1986 de 10 de enero por el que se regulan la actividad industrial y la prestación.

ES

1



2

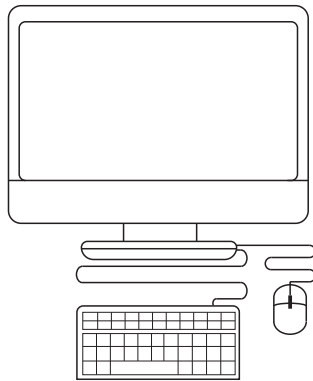

3



IT

1

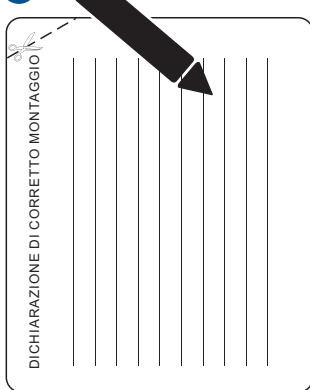

2

